

# VP-330 SERVICE NOTES

Second Edition

APPLICABLE SERIAL NUMBERS & UNITS  
 FLH16 SECTION: 901200- or MOUNTING FLH16 "C" VERSION  
 ENTIRETY: 961450-

Scan by HANS montrealstudios@tango.fr  
 www.blade-tech-sound.com

**SPECIFICATIONS**

|                            |                               |                                 |
|----------------------------|-------------------------------|---------------------------------|
| Keyboard -----             | 49 keys, C-C                  | Output (max. 10Vpp)             |
| Tunable Range --           | ±50 cents                     | H: 0dBm (0.775V rms), 6.3k ohms |
| Microphone Input Impedance | 3k ohms                       | M: -15dBm, 8.6k ohms            |
| Power Consumption-         | 26 watts                      | L: -30dBm, 2.2k ohms            |
| Dimensions -----           | 905 (W) x 370 (D) x 145 (H)mm | Weight -- 14kg                  |

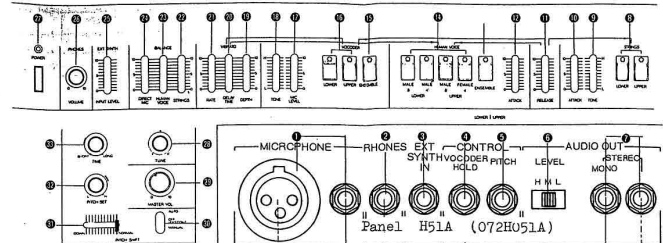
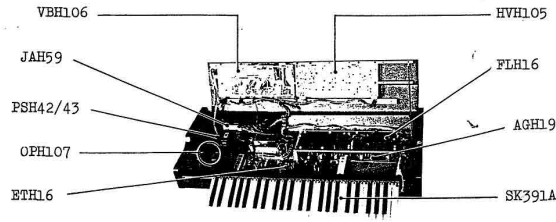
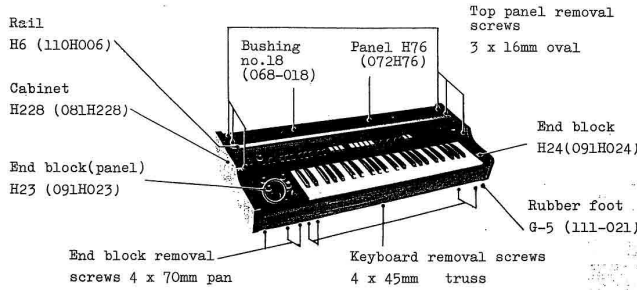

| NO            | PART NUMBER | DESCRIPTION              | PART NAME          |
|---------------|-------------|--------------------------|--------------------|
| 1             | 010-264     | receptacle female        | NC-3FP or D-3M     |
| 2             | 009-036     | jack stereo              | SG-7713            |
| 1, 3, 4, 5, 7 | 009-012     | jack mono                | SG-7622            |
| 6             | 001-297     | switch slide             | HSW-0372-01-030    |
|               | 13129712    | switch tablet-push w/LED | KHC-11901          |
| 8, 14         | 016H010     | tablet white             | tablet H10         |
|               | 016H012     | tablet orange            | tablet H12         |
| 15, 16        | 016H014     | tablet green             | tablet H14         |
|               | 016H017     | tablet yellow            | tablet H17         |
| 9, 11         | 029-447     | pot. 10kA, VR1, VR8      | LFB3R-C20A14       |
|               | 016H004     | knob                     | knob H4            |
| 10            | 029-453     | pot. 1MA, VR2            | LFB3R-C20A16       |
| 12, 17        | 029-450     | pot. 100KA, VR1, VR3     | LFB3R-C20A15       |
| 18, 20-25     | 029-447     | pot. 10KA, VR1-4, VR7-9  | LFB3R-C20A14       |
| 19            | 029-459     | pot. 10KB, VR6           | LFB3R-C20B14       |
| 26            | 13219309    | pot. 10KA, VR10          | VM10EK25A14        |
|               | 016-056     | knob small               | knob no.56         |
| 27            | 019-028     | LED                      | TLR-124            |
|               | 001-        | switch power             | SDA- detail P/LIST |
| 28            | 13219234    | pot. 20KB, VR4           | VM10RK20B24        |
| 29            | 13219759    | pot. 10KB x 2, gang, VR5 | GM70RK20B14        |
|               | 016-057     | knob large               | knob no.57         |
| 30            | 001-202     | switch lever             | SLE-643-18P        |
| 31            | 029-472     | pot. slide, 100KB, VR3   | LFB3R-C16B15L      |
| 32            | 028-762     | pot. 50KB, VR2           | VM10RK20B54        |
| 33            | 13219231    | pot. 500KA, VR1          | VM10RK20A55        |

COMPARISON BETWEEN VERSIONS

|                            | SERIAL NUMBERS          |                        | COMPATIBILITY & REMARKS  |
|----------------------------|-------------------------|------------------------|--|
|                            | UP TO 951449            | WITH 961450            |  |
| KEYBOARD                   | SK-191B                 | SK-361A                | NO   |
| TABLET SW.                 | Rocker                  | Push with LED          | NO   |
| GENERATOR (Wafer terminal) | AGH17 (Vertical & L)    | AGH19 (All vertical)   | YES<br>Modification needs<br>Connector housing conversions                               |
| MODULATOR (BBD)            | ETH09 (SAD512, SAD1024) | ETH16 (MH3004, MH3009) | NO   |
| FILTER                     | FLH16 A/C               | FLH16 C                | YES<br>(C version S/N 901200 - ) (B not in use)<br>A and C require different adjustment. |
| HUMAN VOICE                | HVH56                   | HVH105                 | NO   |
| VIBRATO                    | VBH58                   | VBH106                 | NO   |

|              | SERIAL NUMBERS |  | COMPATIBILITY & REMARKS                |
|--------------|----------------|--|--|
|              | UP TO 951449   | WITH 961450                                      |  |
| PITCH        | OPH60          | OPH107   | NO<br>Circuit: identical               |
|              |                | OPH111   | Pertain to Tab switches                |
|              |                | OPH112   |  |
|              |                | OPH113   |  |
|              |                | OPH116   | Sub-circuit to FLH16C<br>S/N 961500 -- |
| FUSE PCB     |                | OPH67 (100V)<br>OPH68 (117V)<br>OPH69 (220/240V) |  |
| JACK PCB     |                | JAH59  |  |
| POWER SUPPLY |                | FSH42 (100/117V) FSH43 (220/240V)                |  |

1 2 3 4 5 6 7 8 9 10 11 12 13 14 15 16 17 18 19 20 21 22 23 24 25 26 27 28 29 30 31 32 33 34 35 36 37 38 39

A  
B  
C  
D  
E  
F  
G  
H  
I  
J  
K  
L  
M  
N  
O

Scan by HANS montrealstudios@terra.es  
www.oldschool-sound.com

VP-330 BLOCK DIAGRAM  
Serial Number 961450-

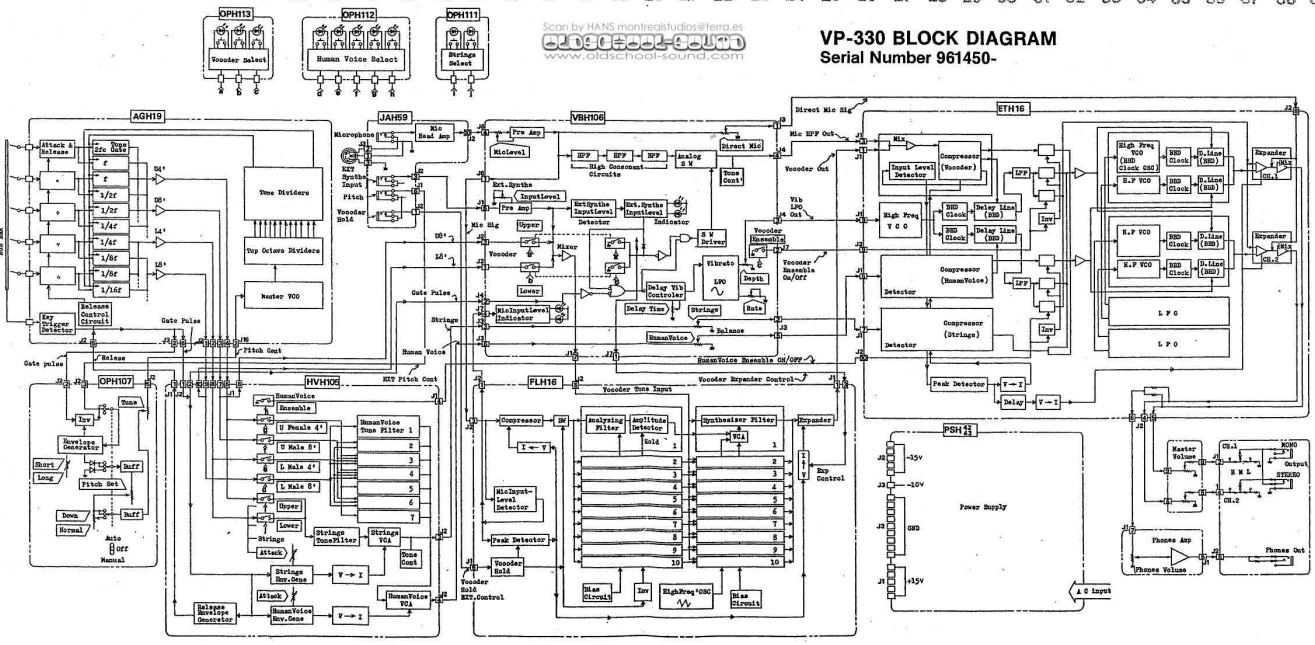

CT. 25, 1980

CIRCUIT DESCRIPTION

-General-

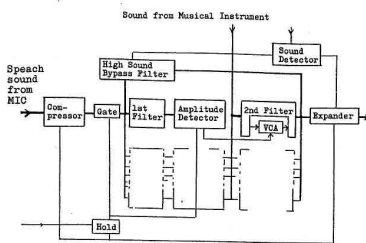

In the vocoder, a signal from a mic is frequency-analyzed through a group of filters to provide a frequency spectrum featuring human voice. Then the spectrum is duplicated at another group of musical sound filters to obtain the functions equivalent to human mouth and throat and thus to facsimile human voice with musical instrument sound.

1. ANALYZING (FIRST) FILTER AND AMPLITUDE DETECTOR

A mic signal is resolved by a group of filters into frequency band components which are amplitude-detected and routed to the VCAs of the Synthesizer (second) Filters. Passing through the 2nd filters, signals are controlled in volume at VCA by the control voltage coming from corresponding frequency band of the 1st filter.

2. SYNTHESIZER (SECOND) FILTER AND VCA

Like the 1st filter, a musical sound being supplied into the 2nd filters is resolved into frequency spectrum components which are proportional to the 1st filters' output in amplitude. The resultant sound spectrum and volume of 2nd filters outputs are analogous to those of the mic signal. Thus, uniform sound spectrum would be ideal for reproduction of human voice, but it is no longer of a musical sound.

3. COMPANDER

The compander is a combination of a compressor and an expander. The compressor reduces input signal range in amplitude, outputting voltages smaller in amplitude range than that of its input voltage. On the contrary, the expander, for a given range of amplitude input voltages, produces a larger amplitude range of output voltages. Thus, restores signal voltages to their original amplitudes.

4. HIGH SOUND BYPASS FILTER (RESONANT FILTER)

Since sounds from musical instruments rarely include high frequency components such as "fricative" in human voice, the 2nd filter has no spectrum to respond to. Furthermore, such a sound hardly relating to musical intervals, is separated from a mic signal, routed to this circuit and re-mixed with the 2nd filter outputs.

5. MUSICAL SOUND DETECTOR

This circuit obstructs the 2nd filter outputs as long as a musical instrument sound is absent and drives the compander and the bypass filter when the sound is sensed.

6. HOLD CIRCUIT

This enables vocoder to hold its output during an interruption in the mic signal, e.g. while the singer inspires. This effect can find some other useful applications. In hold mode, Hold circuit retains sound spectrum and volumes by maintaining voltages constant; at Amplitude Detector and at Expander. The Compressor gain is minimized and the voice Gate is turned off so as to keep voice unchanged even though mic input signal is changing.



CIRCUIT DESCRIPTION -Detail-

1. AGR19

1-1 Master Oscillator

The frequency is determined by the capacitance of D149, variable diode. The pitch is shiftable one octave with the change of voltage across D149 and is stable within 15 cents at the working temperatures of 0° to 40°C (+32° to 104° F). After replacing the components or repairing at VCO or power supply stages, frequency check or re-tuning may be required, but they should be made only after soldered portions are restored to their original temperature.

1-2 Tone Divider, Tone Gate

The Master VCO output is divided into one half in I07 and then subdivided into twelve top octave notes in I08. The lower octaves for each of the 12 notes are provided by frequency dividers, I01-I06, and are distributed to the base of particular transistor choppers, Q2, Q3, etc. (hereafter utmost circuit in the diagrams represents the same family). Q2 in this case serves as a Tone Gate.

1-3 Key Trigger Detector

Consists of Q153, Q154 and Q157, detects current variables along the bus bar caused by the on/off of the key contacts, which are transferred to Q157 collector, shaped into gate signal.

1-4 Release Control

This circuit, composed of Q155 and Q156, controls the Q1 discharge rate, generating an envelope for the Tone Gate according to the gate signal and the signal from HVH105, Release Control Generator.

When the key is pressed, a ground is placed on Q155 collector for approximately 50ms, discharging capacitor C1 to zero volt. This erases remaining envelopes of precedent played keys, and then, Q155 and Q156 develop a new envelope voltage proportional to a signal from Envelope Generator.

2. HVH105

2-1 Release Envelope Generator

The circuit consists of Q1, Q2 and Q3. While key(s) is pressed, connection terminal J1-1 on HVH105 is held at a voltage set by RELEASE knob. When the key is released, the voltage decays along with the envelope shaped by the circuit constant, causing the Release Control on AGR19 to discharge C1 through D1.

3. PVR16

3-1 Compander

This Compander system is composed of the Mic Input Detector IC2 (full-wave rectifier), Peak Detector IC1, V-1 Converters IC3, IC5, IC8 and IC12, Compressor IC3, IC4, and Expander IC8, IC9. One half (positive or negative) of compressor output is 10V maximum. Gains of the Expander and Compressor are opposite to each other. That is, when the amplitude of one circuit increases, that of the other decreases. When the tablets "Vocoder-UPPER-LOWER" are off, and the EXT. SYNTH input is less than a certain level, the Expander output remains at the minimum since the EXPANDER control Q13 turns on.

3-2 Analyzing Filter

Ten BPFs with a high Q, composed of ICs (e.g. IC10 and IC15) and associated Rs and Cs, divide an input signal among them, covering 170Hz-7kHz, and let particular bands pass through. A mic signal from Compressor is preemphasized, accommodated by BPFs corresponding to the spectrum, routed to D1 for peak amplitude detection and smoothed. The voltage connects to VCA in the next filter, Synthesizer Filter.

3-3 Vocoder Hold

Q1, Q2, Q3 and Q4 make up this circuit. When Hold jack circuit opens, and 50ms later, the Q4 output increases in the positive direction to turn on Q6, which in turn places a ground on IC10 input pin, while the voltage through D17 turns off PEE switch IC35 connected to R7 and increases discharge time constant, thus the charging voltage from D1 is held for 2-3sec.

3-4 Synthesizer Filter, VCA

The filter bank slices up instrument sound spectrum into bands in the same way Analyzer Filter does on the speech spectrum. Each slice then connects to voltage-controlled amplifier - VCA IC38, whose gain is proportional to the voltage from the 1st filter amplitude detector. During an absence of signal from Analyzer filter, negative peaks of triangular wave on pin 4 of IC41 is kept plus - determined by VR6 setting, with respect to pin 5, disabling IC38 to switch its gate.

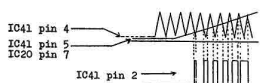

When the voltage from IC20 increases to a some extent, it exceeds lower portion of triangular wave, causing IC41 pin 2 turns to "H" which in turn gates IC38 on. When positive going triangular wave reaches above the voltage on pin 5, pin 2 turns to "L" and IC38 turns off. Thus signal flow rate through IC38 depends on the width of pulse from IC41 and pulse width is proportional to control voltage from IC20.

Fulsating rectified signals are smoothed while they are passing through the next smoothing filter consisting of IC30 and are sent to Expander.

Since the switching cycle of IC38 on and off is sufficiently faster than those of musical signals, the filter gain is proportional to the on/off time ratio of the switching.

Overall frequency response of the synthesizer filter is made to equal de-emphasized characteristics: the higher the frequency, the higher resistance has R21 (the same number for the resistors in ten bands).

3-5 Expander

Like the compressor, the gain of Expander, IC8 and IC9, is controlled by the voltage from IC1 whose direction is opposite to that for the compressor.

4. VPH106

This HPF allows only high-frequency components of the signal from the mike amp to pass so as to compensate for high-frequency ranges incapable of reproduction by vocoder circuits. Similar to expander output on and off circuit on FLH16, the gate switch Q5 is provided not to output signals from the HPF while the vocoder circuit operating conditions are not readily prepared.

5. OPH107

This circuit has basically the same configuration with the OPH29 in the RS905 Roland String Ensemble. See the diagram on page 11 of RS905 Service Notes for easier understanding.

5-1 AUTO

Envelope Generator Q1 and Q3 outputs voltage, when triggered by the gate signal, increases up to the voltage set by PITCH SET and then decays. Level Sustain and Decaytime are made longer as TIME knob being set toward LONG.



5-2 OFF (EXTERNAL CONF)

When the EXT PITCH jack connection is not made, TIME, PITCH SET and NORMAL-DOWN settings are invalid.

When PITCH jack opens, the Q5 collector holds the voltage according to PITCH SET setting and when the jack is closed, the voltage varies in accordance with TIME set.

5-3 MANUAL

In this mode, the trigger and TIME are independent of the GATE. The maximum shift voltage is determined by PITCH SHIF. Thus, manual range variation is possible within the range by controlling the knob.

6. JAH59

The gain of mike head amp is 20dB.

PARTS LIST

CASING

|          |               |         |            |
|----------|---------------|---------|------------|
| 072H076  | Panel         | H76     | top        |
| 072H051A | Panel         | H51A    | rear       |
| 061H228  | Cabinet assy  | H228    |            |
| 059H008  | Hinge         | H8      |            |
| 111-021  | Rubber foot   | G-5     |            |
| 091H023  | End block     | H23     | L/H        |
| 091H024  | End block     | H24     | R/H        |
| 068-018  | Bushing no.18 |         | music rack |
| 110H006  | Rail          | H6      | music rack |
| 004H004  | Keyboard      | SK-391A |            |

KNOB, TABLET

|         |        |       |            |
|---------|--------|-------|------------|
| 016H004 | Knob   | H4    | slide pot. |
| 016H010 | Tablet | H10   | white      |
| 016H012 | Tablet | H12   | orange     |
| 016H014 | Tablet | H14   | green      |
| 016H017 | Tablet | H17   | yellow     |
| 016-056 | Knob   | no.56 | small      |
| 016-057 | Knob   | no.57 | large      |

SOCKET

|          |            |                                |           |
|----------|------------|--------------------------------|-----------|
| 009-012  | Jack       | S9-7622                        | pc mount. |
| 009-036  | Jack       | S9-7713                        | stereo    |
| 13429601 | Receptacle | HA-16FR-3S or (NO-3FP or D-3M) | female    |

SWITCH

|          |               |        |          |
|----------|---------------|--------|----------|
| 001-258  | SDA1S-A-1     | power  | 100V     |
| 001-259  | SDA2S-A-1     | power  | 117V     |
| 001-260  | SDA4S-A-1     | power  | 220/240V |
| 001-297  | HSW-0372-1-30 | slide, | LEVEL    |
| 001-202  | SLB-643-18P   | lever, | AUT/NORM |
| 13129712 | KHO-11901     | push,  | tablet   |

PCB ASSY

|          |        |                        |
|----------|--------|------------------------|
| 114H019  | AGH19  | (pcb 052H187)          |
| 149H105  | HVH105 | (pcb 052H254)          |
| 149H106  | VPH106 | (pcb 052H257)          |
| 149H107  | OPH107 | (pcb 052H244)          |
| 149H111  | OPH111 | (pcb 052H255-1)        |
| 149H112  | OPH112 | (pcb 052H255-2)        |
| 149H113  | OPH113 | (pcb 052H255-3)        |
| 149H118  | OPH118 | (pcb 052H294)          |
| 145H016C | FLH16C | (pcb 052H189C)         |
| 146H042A | FSH42A | (pcb 052H183A)100/117V |
| 146H043A | FSH43A | (pcb 052H183A)220/240V |
| 151H016  | SHH16  | (pcb 052H256)          |
| 149H057A | OHH57A | (pcb 052H185A) 100V    |
| 149H058A | OHH58A | (pcb 052H185A) 117V    |
| 149H069A | OHH69A | (pcb 052H185A)220/240V |

FUSE

|         |           |     |          |
|---------|-----------|-----|----------|
| 008-041 | S9A 1.0A  | GSA | 117V     |
| 008-066 | SERMO T1A |     | 220/240V |

COIL TRANSFORMER

|           |           |  |          |
|-----------|-----------|--|----------|
| 022-129   | BO-855    |  | 180μH    |
| 022H025-A | PT.H250-A |  | 117V     |
| 022H025D  | PT.H25D   |  | 220/240V |

POTENTIOMETER

|           |               |          |            |
|-----------|---------------|----------|------------|
| Rotary    |               |          |            |
| 132119234 | VMLOR20B24    | 20KB     | TUNE       |
| 13219309  | VMLOR25A14(L) | 10KA     | PIN-VOL    |
| 13219759  | GM7OR20B14(L) | 10KB x 2 | MASTER-VOL |
| 13219231  | VMLOR20A55(L) | 500KA    | TIME       |
| 028-762   | VMLOR20B54(L) | 50KB     | PFC-SET    |

|         |               |       |           |
|---------|---------------|-------|-----------|
| Slider  |               |       |           |
| 029-447 | LFP3R-020A14  | 10EA  |           |
| 029-459 | LFP3R-020B14  | 10KB  | VID-DEPTH |
| 020-450 | LFP3R-020A15  | 100KA | MIK-LEVEL |
| 029-472 | LFP3R-016B15L | 100KB | PFC-SHIFT |
| 029-453 | LFP3R-020A16  | 1MA   | STRM-ATXK |

|         |        |  |       |
|---------|--------|--|-------|
| Trimmer |        |  |       |
| 030-467 | SR-13R |  | 22KB  |
| 030-461 | SR-13R |  | 2.2KB |
| 030-463 | SR-13R |  | 4.7KB |
| 030-471 | SR-13R |  | 100KB |
| 030-459 | SR-13R |  | 1KB   |
| 030-469 | SR-13R |  | 47KB  |

RESISTOR

|                    |         |  |      |
|--------------------|---------|--|------|
| Metal film 1/4W 1% |         |  |      |
| 044-830            | CRB25FX |  | 1K   |
| 044-862            | CRB25FX |  | 1.2K |
| 044-849            | CRB25FX |  | 220K |

|             |         |  |                 |
|-------------|---------|--|-----------------|
| Carbon 1/2W |         |  |                 |
| 13829801H0  | 10 ohms |  | flame retardant |

CAPACITOR

|            |       |       |                   |
|------------|-------|-------|-------------------|
| 035-145    | 50pF  | 50V J | polystyrene       |
| 035-156    | 150pF | 50V J | polystyrene       |
| 032-241    | 10μF  | 16V   | electro. bi-polar |
| 13639943M0 | 2.2μF | 50V   | electro. bi-polar |

|                  |        |            |       |
|------------------|--------|------------|-------|
| Mylar 50V G (2%) |        |            |       |
| 13549201T0       | 0018pF | 13549207T0 | 012pF |
| 13549202T0       | 0027pF | 13549208T0 | 018pF |
| 13549203T0       | 0033pF | 13549209T0 | 027pF |
| 13549204T0       | 0039pF | 13549210T0 | 039pF |
| 13549205T0       | 0056pF | 13549211T0 | 047pF |
| 13549206T0       | 0082pF | 13549212T0 | 056pF |

1980 OCT 25

VP-330

SEMICONDUCTOR

- Transistor
- 017-024 2SA733-P
- 15129122 28C1923-R (280381-R)
- 017-129 2807528-0
- 15119805 28B834-0
- 15129121 28C2021-R
- 15119602 28B647-0
- 15129602 28B667-0
- 017-106 28C1815-GR
- 017-155 28A1015-GR
- 017-146 28B605-L
- 017-072 28D971-L
- 017-023 28C945-P
- 017-010 28D880-0
- 017-014 28K30A-Y FET
- 017-016 28K30A-GR FET
- Diode
- 15019626 05Z-11U Zener
- 018-086 SV0303 varicap
- 018-014 1S2473
- 019-028 T1R-124 LED red
- 019-029 T1G-124 LED green
- 018-114 1SR35-200 or 1N4003
- IC
- 020-156 AY-3-0214 chromatic divider
- 1515912470 T04093BP quadruple 2-in NAND
- 15159115N0 μPD4066C quad bilateral switch
- 020-227 T04520BP dual binal up counter
- 020-041 T04013BP dual D flip flop
- 020-064 μP04558C dual op amp
- 020-208 LF353 FET dual op amp
- 020-100 TLO82CP dual FET op amp
- 020-160 BA662A op amp transconductance
- 020-083 T04016BP quad bilateral switch
- 020-215 MN3009 BBD 256-stage
- 020-063 MN3004 BBD 512-stage
- 020-228 TA7179M regulator
- 15189113 AN6912 quad comparator

1 2 3 4 5 6 7 8 9 10 11 12 13 14 15 16 17 18 19 20 21 22 23 24 25 26 27 28 29 30 31

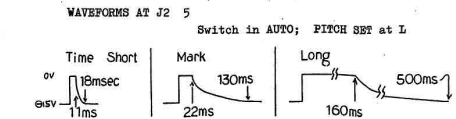
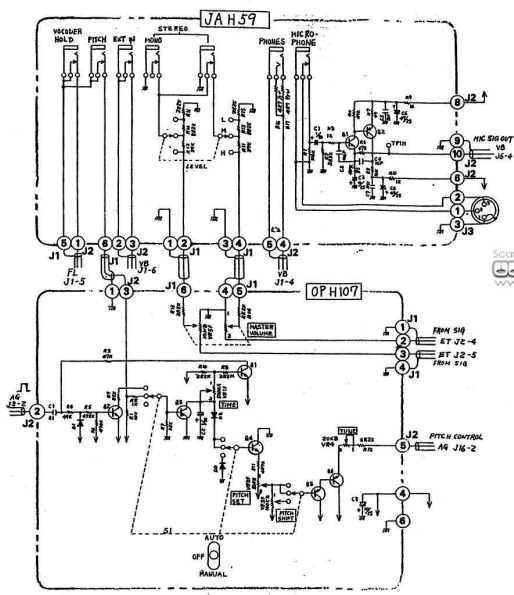

- OTHERS
- 048-084 Heatsink RH-15
  - 048H018 Heat sink no.18
  - 068-032 Collar bushing NA-305
  - 068-034 Collar bushing NB-300
  - 064H200 Feb holder D10-BB-SN

JAH59 (149H059)  
(Etch mask 052H198)

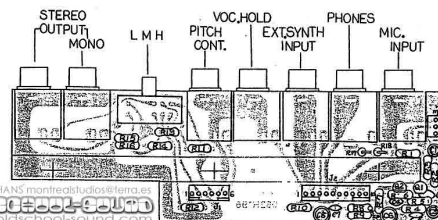

OPH107 (149H107)  
(Etch mask 052H244)  
View from foil side

- 28A1015-GR
- 28C1815-GR
- Diode 1S2473
- LED T1R-124 (red)
- Pipe H:16mm
- longer lead

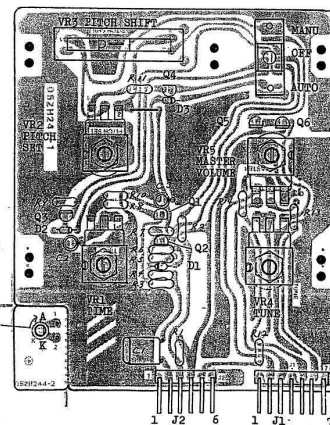

A  
B  
C  
D  
E  
F  
G  
H  
I  
J  
K  
L  
M  
N  
O  
P  
Q  
R  
S  
T  
U

VP-330

OCT. 25, 19

F 10 11 12 13 14 15 16 17 18 19 20 21 22 23 24 25 26 27 28 29 30 31 32 33 34 35 36 37 38 39

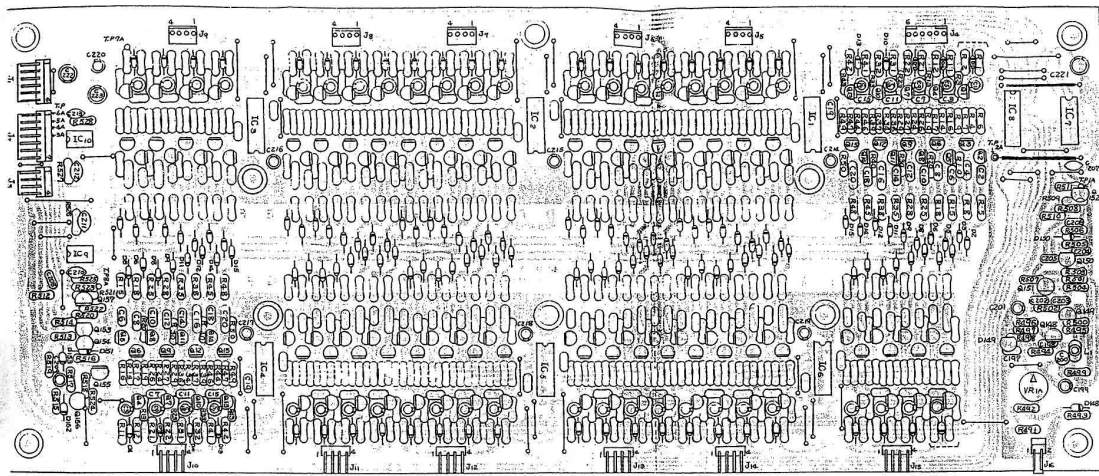

**AGH19 (144H019)**  
(Etch mask 052H187)

Interchangeable with AGH17

Left, J1-3, J10-16 show wafer terminals on AGH-17 in old model, which are, on AGH19, of the styles shown below.

When used as a replacement for AGH17, AGH19 needs some new connector housings to mate the vertical pins.

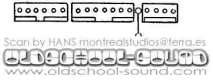

Scan by HANS.morheut@tut.at  
www.oldschool-sound.com

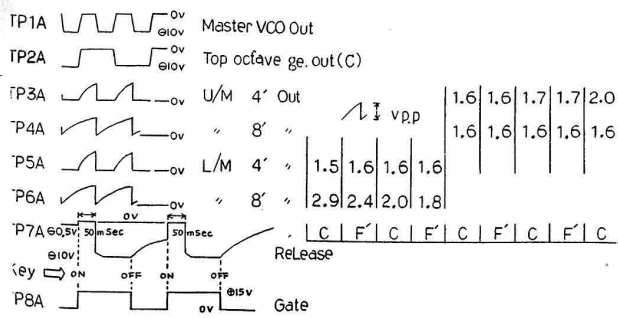
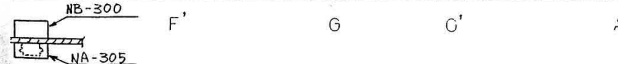

**TUNING**

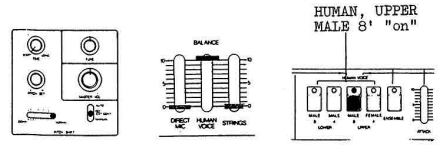

The Master VCO should be retuned when,  
1. voltages changed in DC lines after modification or repairs at the power supplies;  
2. components in the VCO stage are replaced.  
When soldered, allow for few minutes to dissipate.  
Set controls as illustrated above.  
Set VRL1A for 442Hz at OUTPUT jack with A3 key being pressed.

- SR-19R wiper
- 28C7520-0
- 28C381-R
- 28C1815-GR
- 28A733 -P(R)
- 28A1015-GR
- Polystyrene cap.
- Ceramic capacitor
- Mylar capacitor
- Electrolytic cap.
- 182473 or 181555

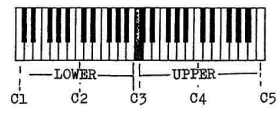

1980  
 1 2 3 4 5 6 7 8 9 10 11 12 13 14 15 16 17 18 19 20 21 22 23 24 25 26 27 28 29 30 31 32 33 34 35 36 37 38 39 40

VP-330

AGH19 surface mounting  
 C<sub>2</sub> ~ C<sub>5</sub> only  
 C note only

AY-3-0214

R refers to Radix (decimal) point.

| C    | C <sup>0</sup> ~ F | F <sup>0</sup> , G | G <sup>0</sup> , A | A <sup>0</sup> , B |
|------|--------------------|--------------------|--------------------|--------------------|
| C 2  | R0015              |                    |                    |                    |
| C 4  | R0088              |                    |                    |                    |
| C 6  | R0033              | R0022              | R0018              | R0015              |
| C 8  | R015               | R01                |                    |                    |
| C 10 | R0088              | R0047              |                    |                    |
| C 12 | R033               | R022               |                    |                    |
| C 14 | R015               | R01                |                    |                    |
| C 16 | R068               | R047               |                    |                    |
| C 18 | R033               | R022               |                    |                    |
| C 20 | R12                | R1                 |                    |                    |
| C 3  | R001               |                    |                    |                    |
| C 7  | R001               |                    |                    |                    |
| C 11 | R001               |                    |                    |                    |
| C 15 | R0022              | R0015              |                    |                    |
| C 19 | R0039              | R0027              |                    |                    |
| R 38 | 330K               | 390K               |                    |                    |
| R 48 | 220K               | 270K               |                    |                    |

VP-330 KEYBOARD, SK-391A PARTS

| NO | PART NO | DESCRIPTION         |
|----|---------|---------------------|
| 1  | 106H026 | Natural key C F     |
| 1  | 106H027 | Natural key D       |
| 1  | 106H028 | Natural key E B     |
| 1  | 106H029 | Natural key G       |
| 1  | 106H030 | Natural key A       |
| 1  | 106H031 | Natural key C' F'   |
| 2  | 106H032 | Sharp key black     |
| 3  | 070H029 | Key spring H29      |
| 4  | 061H085 | Chassis H85         |
| 5  | 068H004 | Guide bushing H4    |
| 6  | 101HL42 | Level felt HL42     |
| 7  | 071H044 | Contact leaf H44    |
| 8  | 071H048 | Bus bar 49p H48     |
| 9  | 043H007 | Switch unit 12p H7  |
| 9  | 043H008 | Switch unit 13p H8  |
| 10 | 104H029 | Bus bar holder H29  |
| 11 | 062H024 | Chassis bracket H24 |
| 12 | 098H006 | Key stopper H6      |

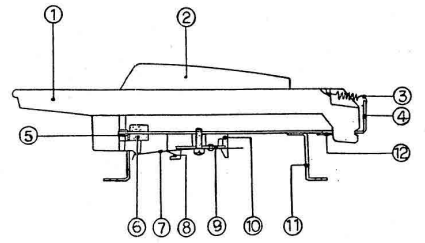
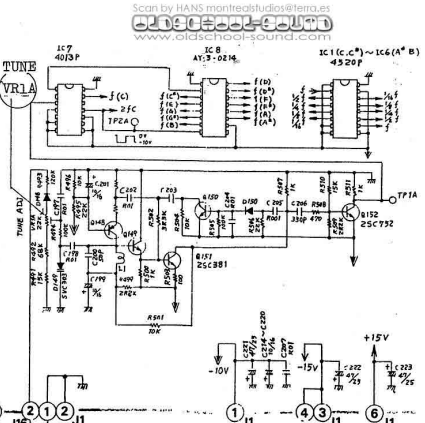
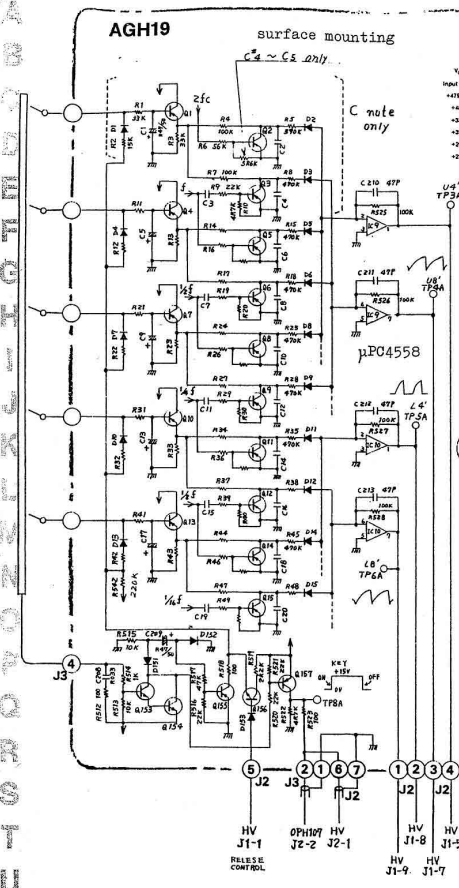

UNLESS OTHERWISE NOTED:  
 PNP transistors - 2SA733-P or 2SA1015-GR  
 NPN transistors - 2SC1815-GR  
 Diodes ----- 1S2473 or 1S1555

A  
B  
C  
D  
E  
F  
G  
H  
I  
J  
K  
L  
M  
N  
O  
P  
Q  
R  
S  
T  
U  
V  
W  
X  
Y  
Z

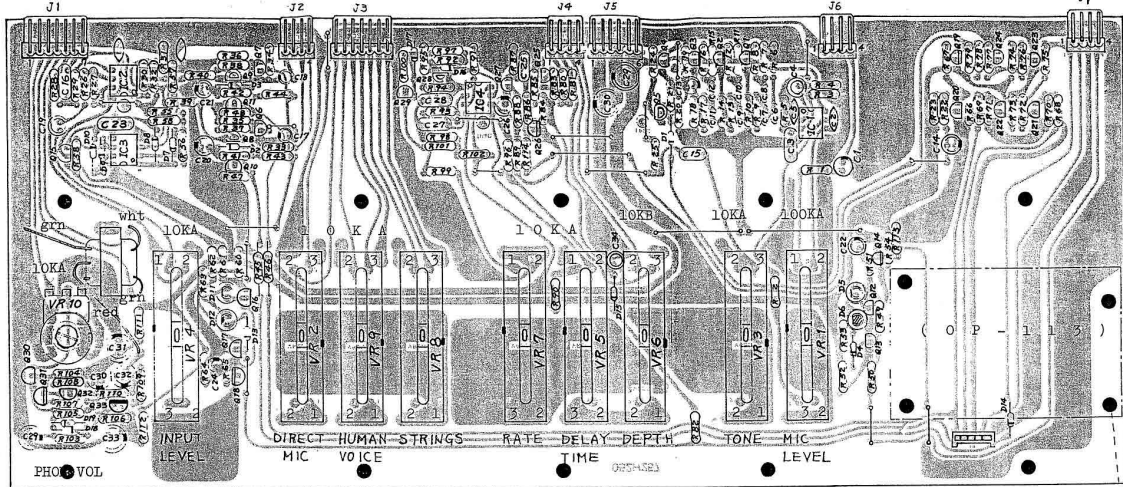

**BH106 (149H106)**  
(pcb 052H257)

- 28A1015- GR or Y
- 28C1815- GR or Y
- ⤴ 182473 or 181555
- Mylar R0022uF Mylar
- ⊙ 28K30A-GR
- R25J
- Ceramic cap.
- ⊙ Longer lead LED TL124 red
- ⊙ Pipe 6 x 18mm LED TL124 green

Scan by HANS morhecoltdow@tema.nl  
www.oldschool-sound.com

**4520B (AGH19)**  
DUAL BINARY UP COUNTER

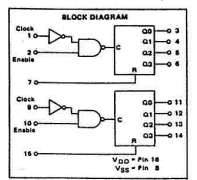

| TRUTH TABLE |        |       |                   |
|-------------|--------|-------|-------------------|
| CLOCK       | ENABLE | RESET | ACTION            |
| 1           | 0      | 0     | Increment Counter |
| 0           | 0      | 0     | Increment Counter |
| X           | X      | 0     | No Change         |
| 0           | 0      | 0     | No Change         |
| 1           | 0      | 0     | No Change         |
| X           | X      | 1     | GG thru Q3 = 0    |

X = Don't Care

**4013B**  
DUAL TYPE D FLIP-FLOP

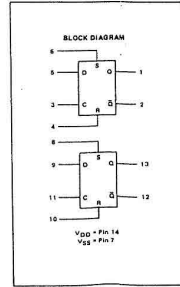

| TRUTH TABLE |      |         |     |   |       |
|-------------|------|---------|-----|---|-------|
| INPUTS      |      | OUTPUTS |     |   |       |
| CLOCK       | DATA | RESET   | SET | Q | Q-bar |
| 0           | 0    | 0       | 0   | 0 | 1     |
| 1           | 0    | 0       | 0   | 1 | 0     |
| X           | X    | 0       | 0   | 0 | 0     |
| X           | X    | 1       | 0   | 0 | 1     |
| X           | X    | 0       | 1   | 1 | 0     |
| X           | X    | 1       | 1   | 1 | 1     |

X = Don't Care  
1 = Level Change

**OPH113 (149H113)**  
(Etch mask 052H255-3)

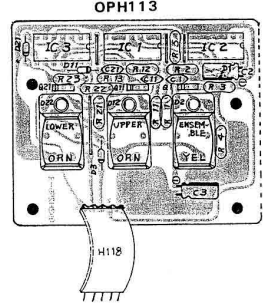

A  
B  
C  
D  
E  
F  
G  
H  
I  
J  
K  
L  
M  
N  
O  
P  
Q  
R  
S  
T  
U  
V  
W  
X  
Y  
Z  
0  
1  
2  
3  
4  
5  
6  
7  
8  
9  
10  
11  
12  
13  
14  
15  
16  
17  
18  
19  
20  
21  
22  
23  
24  
25  
26  
27  
28  
29  
30  
31  
32  
33  
34  
35  
36  
37  
38  
39  
40  
4

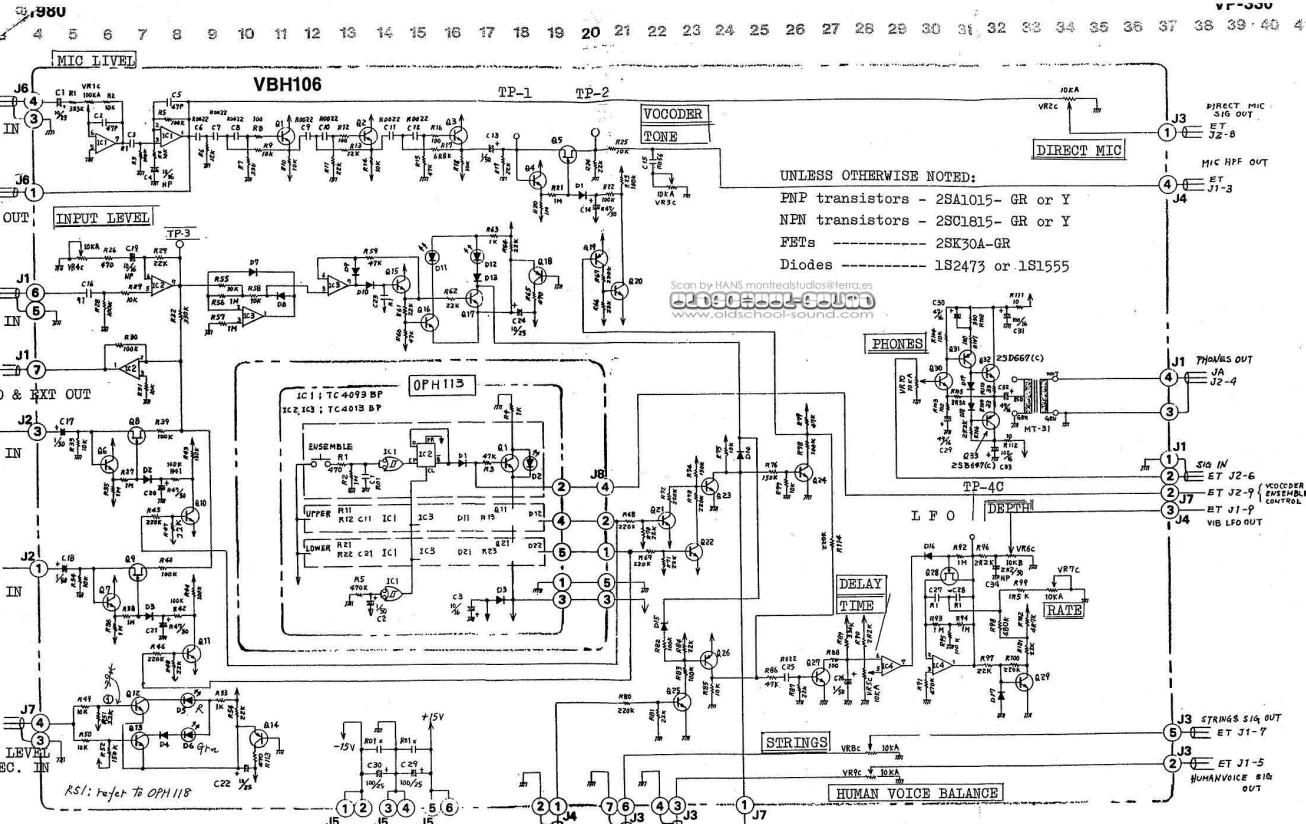

UNLESS OTHERWISE NOTED:  
 PNP transistors - 2SA1015-GR or Y  
 NPN transistors - 2SC1815-GR or Y  
 FETs ----- 2SK30A-GR  
 Diodes ----- 1S2473 or 1S1555

Scan by HANS marfied@tudost@ferret.it  
 www.oldschool-sound.com

LFO TP-4C  
 Vibrato   
 Rate VR:0 . T = 220msec  
 " :10. T = 90 "

LFO TP-4C  
 Delay Time VR:0   
 Key -> on  
 VR:10   
 0.7sec  
 2.2sec

VP-330

OCT. 2

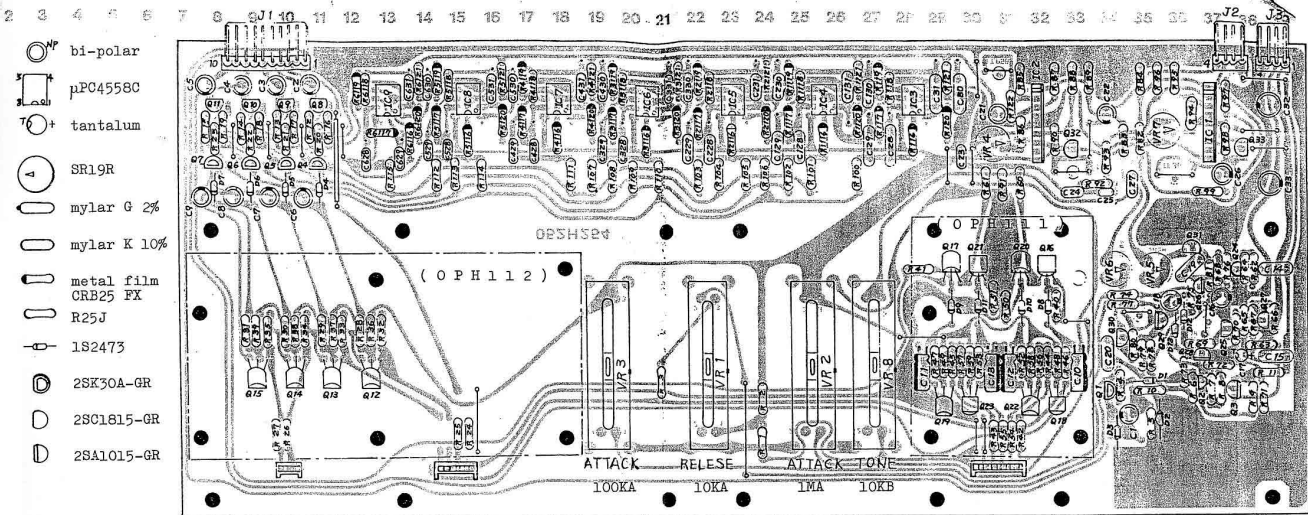

**4093B**

QUAD 2-INPUT "NAND"  
 SCHMITT TRIGGER

EQUIVALENT CIRCUIT SCHEMATIC  
 (1/4 OF CIRCUIT SHOWN)



LOGIC DIAGRAM

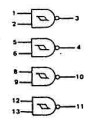

V<sub>DD</sub> = Pin 14  
 V<sub>EE</sub> = Pin 7

Scan by HANS montrealstudios@terra.es  
 HVH105(149H105) (Etch mask 052H254)  
 www.oldschool-sound.com

**OPH112(149H112) (Etch mask 052H255-2)**

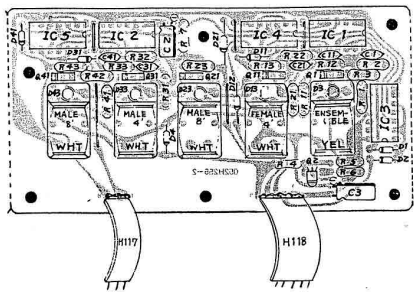

**OPH111(149H111)**

(Etch mask 052H255-1)

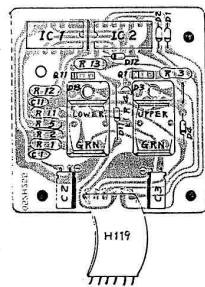

A  
B  
C  
D  
E  
F  
G  
H  
I  
J  
K  
L  
M  
N  
O  
P  
Q  
R  
S  
T  
U  
V

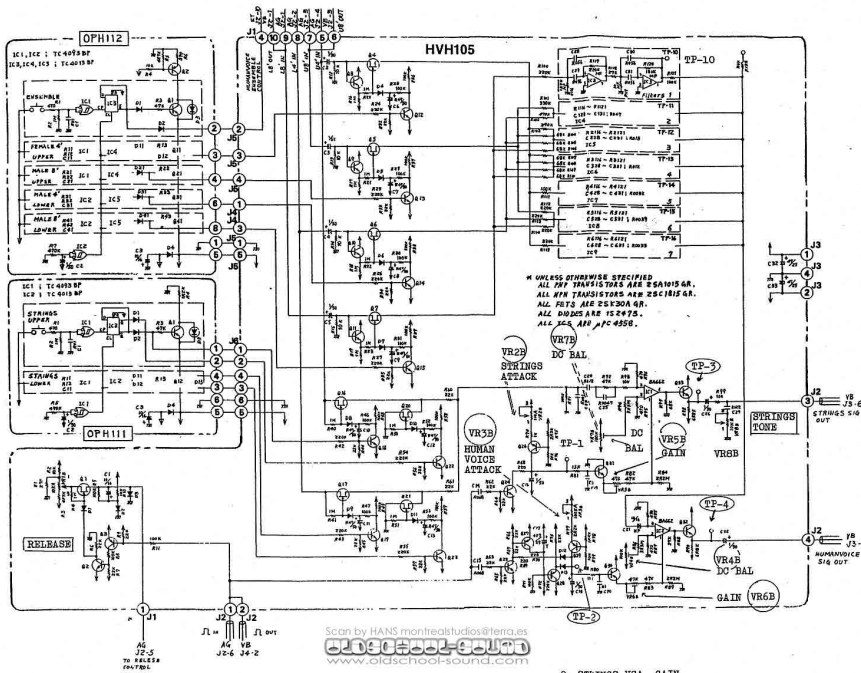

STRINGS VCA (IC 1)

1. STRINGS VCA DC BALANCE

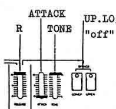

While tapping a key repeatedly, quickly, adjust VR7B for the least DC level variation.

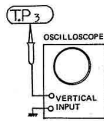

2. STRINGS VCA GAIN (TP-3)

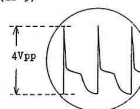

While holding O3 key down, adjust VR5B for the waveform as shown above.

HUMAN VOICE VCA (IC 2)

3. H. VOICE VCA DO BALANCE

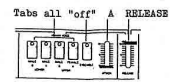

While tapping a key, adjust VR6B for the least DC level variation.

4. H. VOICE VCA GAIN

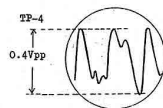
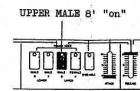

While holding O3 key down, adjust VR6B for the waveform shown above.

1 2 3 4 5 6 7 8 9 10 11 12 13 14 15 16 17 18 19 20 21 22 23 24 25 26 27 28 29 30 31 32 33 34 35 36 37 38 39 40

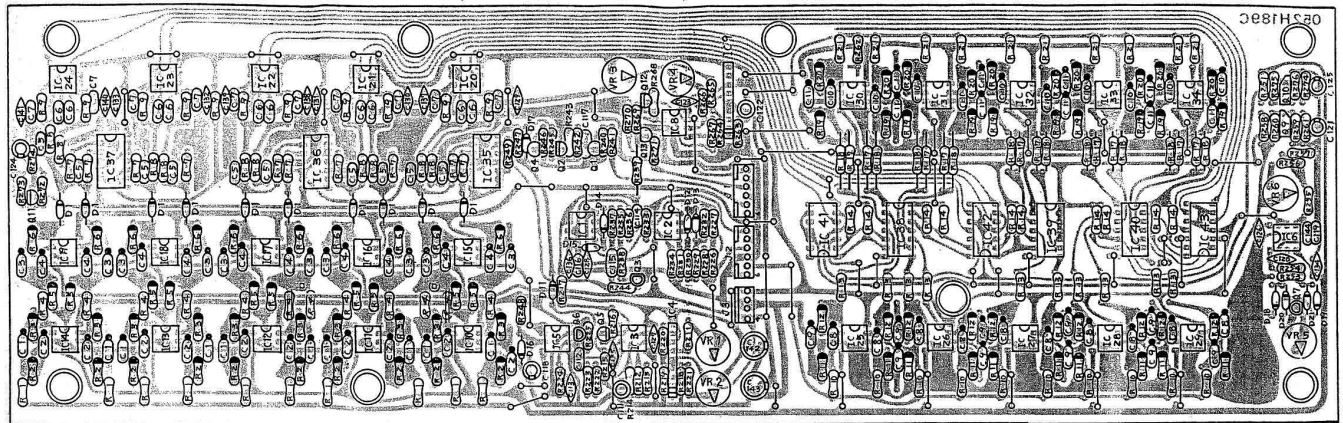

**FLH16C (145H016C)**  
 (Etch mask 052H189C)

For the products bearing Serial Number from 901200 to 951499, or furnished with FLH16C, this and next pages are applicable in combination with the previously issued (Sept. 21, 1979) Service Notes which lacks necessary information on FLH16C.

Scan by HANS montreckstudios@lema.es  
[www.oldschool-sound.com](http://www.oldschool-sound.com)

- carbon ±w 5%
- metal film 1%
- ⊘ 2SA1015-GR
- ⊘ 2SC1815-GR
- ⊘ 2SK30A-Y
- mylar 10%, K
- mylar or polypropylene 2%, G
- 182473
- ◇ ceramic
- ⊖ electrolytic
- ⊖ electro.bi-polar
- SR-19R (2) wiper
- TL082
- uPC4558C
- BA662A
- 2SB605
- 2SD571

TC4016BP -- TC4066BP : interchangeable  
 LF353, XR082, TL082 : functional equivalence.  
 TL082 predominantly in use.

**μPC4558C**  
**TL082C P**  
**LF353N**

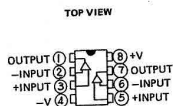

**μPC177C, AN6912**  
**Quad Comparator**  
 Connection Diagram  
 (Top View)

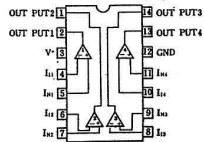

**4016B 4066B**

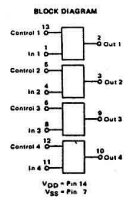
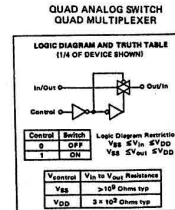

1 2 3 4 5 6 7 8 9 10 11 12 13 14 15 16 17 18 19 20 21 22 23 24 25 26 27 28 29 30 31 32 33 34 35 36 37 38 39 40

A  
B  
C  
D  
E  
F  
G  
H  
I  
J  
K  
L  
M  
N  
O  
P  
Q  
R  
S  
T  
U  
V

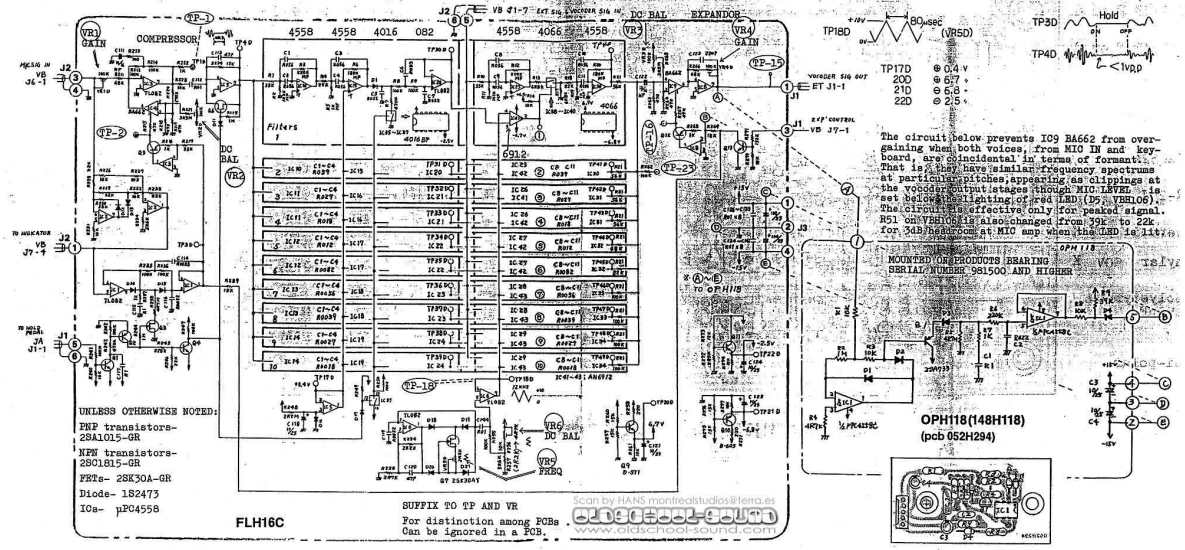







UNLESS OTHERWISE NOTED:  
 FNP transistors-  
 28A1015-GR  
 FNP transistors-  
 28C1815-GR  
 FETs- 28K304-GR  
 Diode- 1S2475  
 ICs- μPC4558

FLH16C

Scan by HANS montrechtstudios@tara.es  
[www.oldschool-sound.com](http://www.oldschool-sound.com)

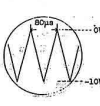
FLH16C ADJUSTMENT

- 1. COMPRESSOR (IC3, IC4) DC BALANCE**  
 (No input signals)  
 Set VR2 at its midpoint.  
 While placing intermittent ground on TP-2 by touching one lead end to the chassis with the other end connected to TP-2, adjust VR2 for minimum DC level variation.  

- 2. COMPRESSOR GAIN**  
 Apply the signal into MIC IN.  
 Adjust VR1 for 20Vpp at TP-1.  

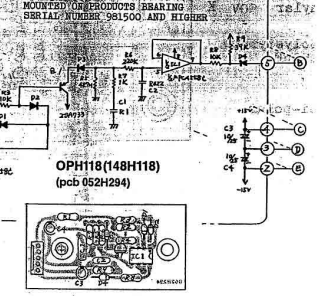
- 3. EXPANDER (IC8, IC9) DC BALANCE**  
 (No input signal)  
 While placing intermittent ground to TP-16 (refer to step 1, COMPRESSOR), adjust VR3 for minimum DC variation.  

- 4. EXPANDER GAIN**  
 Feed the signal into TP-23.  
 Adjust VR4 for 12Vpp at TP-15.  

- 5. TRIANGLE WAVEFORM (IC6) FREQUENCY**  
 Connect oscilloscope to TP-18 through 10:1 probe for the least ill effect to the circuit.  
 Set VR5 for 80µs/cycle.  

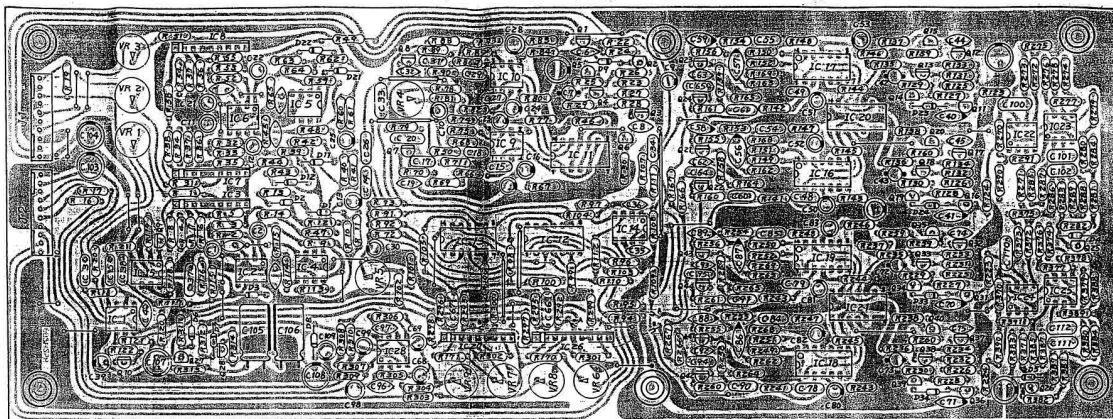
- 6. VCA CUTOFF BIAS (IC6)**  
 Temporarily grounded TP16 and TP20.  
 Feed white signal, not less than 0.4Vpp, into EXT SYNTH IN at rear. Adjust EXT SYNTH-INPUT LEVEL at front so that the red LED is in the condition between flicker and complete light cutoff.  
 Since VR6 determines bias voltage for all filter channels, checking each channel for malfunction is necessary before VR6 is set in place. Set VR6 for the highest duty ratio and check TP-40 thru TP-49 with scope for the signal level. Connect scope to TP-15. Adjust VR6 for the disappearance of the waveform from screen. Excessive turn to set the bias below cutoff point will result in relatively low VCA output voltage.  

The circuit below prevents IC9 BA662 from over-gaining when both voices, from MIC IN and keyboard, are coincidental in terms of format. That is, they have similar frequency spectrums at particular phases, appearing as clippings at the wood's output stages through MIC LEVEL. The circuit is effective only for peaked signal. R21 can be changed from 22k to 22k for 24dB headroom at MIC amp when the LED is lit.



1 2 3 4 5 6 7 8 9 10 11 12 13 14 15 16 17 18 19 20 21 22 23 24 25 26 27 28 29 30 31 32 33 34 35 36 37 38 39

- A (Top View)
- B 28A733 P or Q
- C 280945 P or Q
- D 182473
- E uPC04558C
- F BA662A
- G R-25J
- H ceramic 50V K
- I mylar 50V K
- J polystyrene 150pF
- K bi-polar



**ETH16(151H016) (Etch mask 052H256)**

Scan by HANS montrealstudios@terra.es  
[www.oldschool-sound.com](http://www.oldschool-sound.com)

- L BA662
- M
- N
- O
- P
- Q (Top View)
- R 256-stage
- S Audio signal delay
- T Variable range
- U 0.64-12.8ms
- V S/N ~ 88dB typ.

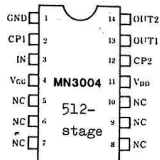

(Top View)

Delay range

2.56-25.6ms

S/N 85dB

Clock Freq.

10-100kHz

**1. VOCODER COMPRESSOR (IC2, IC4) GAIN**

Feed 1kHz, sine wave, 5Vpp into J1-3.

Adjust VR1 for 18Vpp at TP-1.

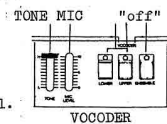

**2. HUMAN VOICE COMPRESSOR (IC6, IC7) GAIN**

Feed 1kHz, sine wave, 10Vpp into J1-5.

Adjust VR2 for 18Vpp at TP-2.

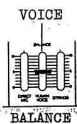

**3. STRINGS COMPRESSOR (IC6, IC8) GAIN**

Feed 1kHz, sine wave, 15Vpp into J1-7.

Adjust VR3 for 18Vpp at TP-3.

STRINGS



**4. MIXING AMP EXPANDERS**

- CH-1 (IC26, IC28) CH-2 (IC27, IC28) -

**4a. DC BALANCE**

While placing intermittent ground on TP-6 by touching a lead end to the chassis with the other end connected to TP-6, adjust VR6 (VR7) for the least DC level variation at TP-17 (TP-18).

VOICE



**4b. GAIN**

Feed 1kHz, sine wave, 10Vpp into J1-5. Adjust VR8 (VR9) for 5Vpp at TP-17 (TP-18).

1 2 3 4 5 6 7 8 9 10 11 12 13 14 15 16 17 18 19 20 21 22 23 24 25 26 27 28 29 30 31 32 33 34 35 36 37 38 39

A  
B  
C  
D  
E  
F  
G  
H  
I  
J  
K  
L  
M  
N  
O  
P  
Q  
R  
S  
T  
U  
V

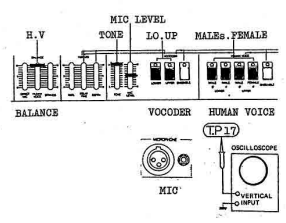
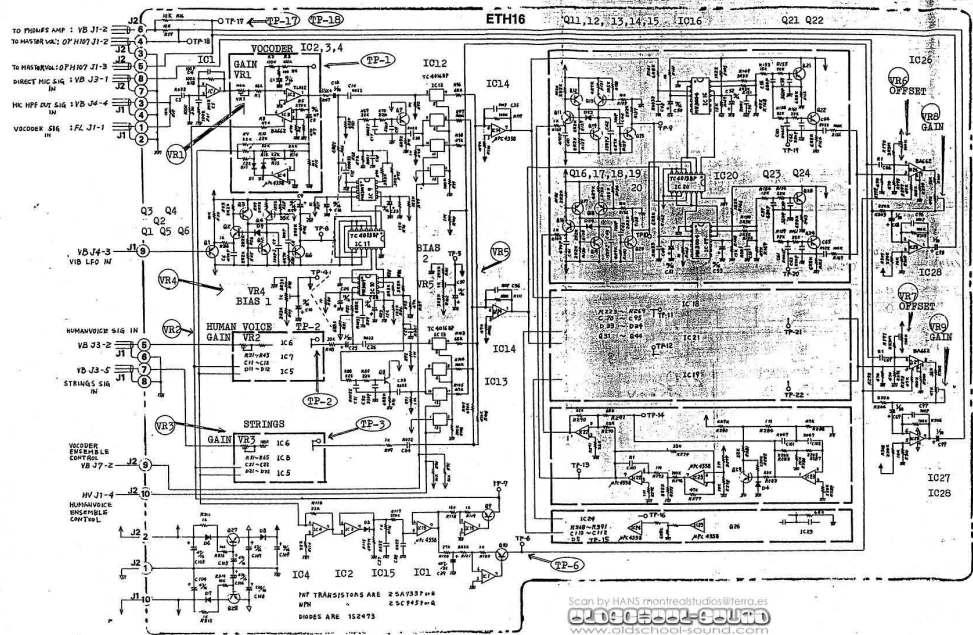

5. BBD BIAS 1 (VIBRATO) IO9, IO10

The purpose of this adjustment is to set BBD operating point to the center.

First, make an adjustment in either mode: **VOODOO** or **HUMAN VOICE**, then, check the waveform in the other mode for saturation.

Scan by HANS from hudson@fero.nl  
www.bobchordsound.com

While pressing many keys, adjust VR4 so that both positive and negative peaks are distortion free or, if not, flattened to the same degree or symmetrically (depends on MIC LEVEL set or the number of the keys being played). This adjustment can be made by listening to the sound through a speaker. The signal at BBD input pin should be set to the level at which BBD output is more or less than distortion. Off-centered operating point causes the sound to be heard as if it were coming from the other speaker or the like. Adjust VR4 for the other tones.

6. BBD BIAS 2 (ENSEMBLE) IO16, IO17, IO18, IO19

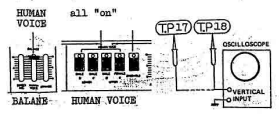

Apply the same procedure described in BIAS 1. Adjust VR5.

A  
B  
C  
D  
E  
F  
G  
H  
I  
J  
K  
L  
M  
N  
O  
P  
Q  
R  
S  
T  
U  
V

**PSH42A (146H042A 100/117V)**  
**PSH43A (146H043A 220/240V)** (Etch mask 052H183A)

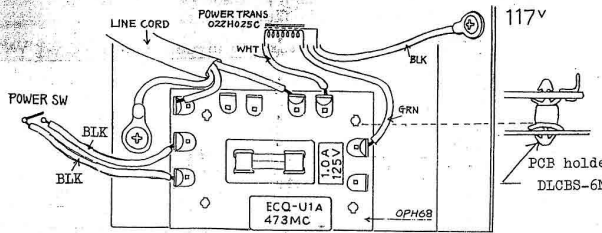
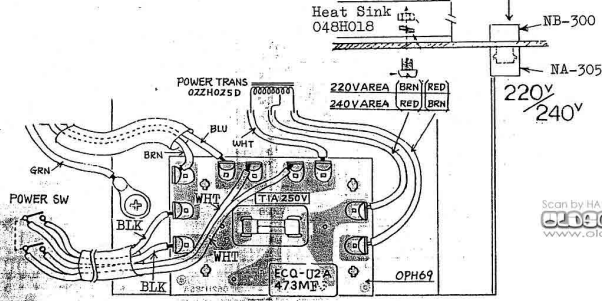
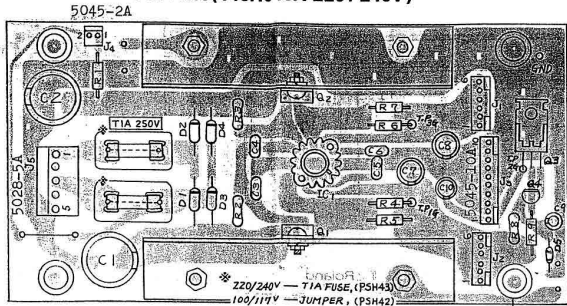

**VP-330**

**OCT 25 1980**

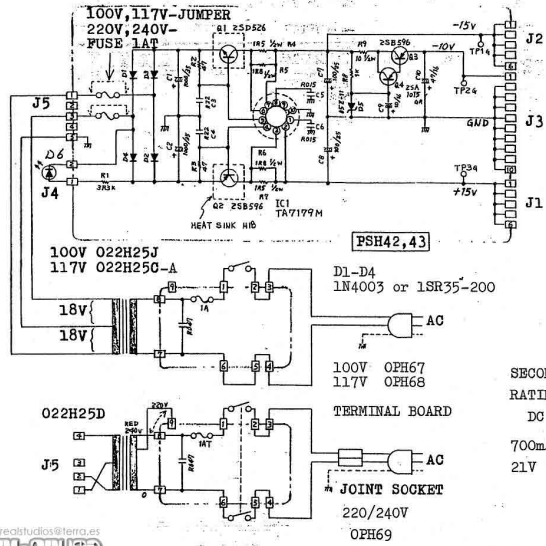

SECONDARY RATINGS  
 DC  
 700mA at 21V

Scan by HANS montrealstudios@terra.es  
[www.oldschool-sound.com](http://www.oldschool-sound.com)

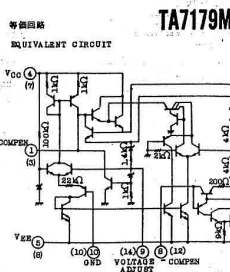

Pin numbers in parentheses are for the plastics type TA7179F only.

最大定格 (Ta=25°C)

| ABSOLUTE MAXIMUM RATINGS |                  |           |      |
|--------------------------|------------------|-----------|------|
| CHARACTERISTICS          | SYMBOL           | RATING    | UNIT |
| 入力電圧                     | +VIN             | 50        | V    |
| Input Voltage            | -VIN             | -30       |      |
| 出力電流                     | +IOUT            | 100       | mA   |
| Output Current           | -IOUT            | -100      |      |
| 消費電力                     | PD               | 625       | mW   |
| Power Dissipation        |                  | 500       |      |
| 動作温度                     | T <sub>opr</sub> | -30 ~ 75  | °C   |
| Operating Temperature    |                  | -30 ~ 75  |      |
| 保存温度                     | T <sub>stg</sub> | -55 ~ 150 | °C   |
| Storage Temperature      |                  | -55 ~ 150 |      |