

# ARP EXPLORER I MODEL 2900 SERVICE MANUAL



ARP INSTRUMENTS, INC.  
320 Needham Street,  
Newton, Mass. 02164  
617 965-9700

*Check [WWW.bleeps-and-peeps.com](http://WWW.bleeps-and-peeps.com) for more Arp OwnersManuals*



# EXPLORER I MODEL 2900 SERVICE MANUAL

## TABLE OF CONTENTS

1. INTRODUCTION	
1.1 DESCRIPTION	3
1.2 SPECIFICATION	3
1.3 SIGNAL FLOW	3
2. 2901 BOARD: Special Effects	
2.1 2901 CIRCUIT DESCRIPTIONS	5
2.2 2901 BOARD TRIMS	6
2.3 2901 TEST POINTS	6
2.4 2901 SCHEMATICS	8
2.5 2901 BOARD LAYOUT	9
3. 2902 BOARD : ADSR, VCF, VCA	
3.1 2902 CIRCUIT DESCRIPTIONS	11
3.2 2902 BOARD TRIMS	12
3.3 2902 BOARD TEST POINTS	13
3.4 2902 SCHEMATICS	14
3.5 2902 BOARD LAYOUT	15
4. 2903 BOARD: Waveform Generator	
4.1 2903 CIRCUIT DESCRIPTIONS	17
4.2 2903 BOARD TRIMS	18
4.3 2903 BOARD TEST POINTS	18
4.4 2903 SCHEMATICS	20
4.5 2903 BOARD LAYOUT	21
5. 2904 BOARD: Power Supply	
5.1 2904 BOARD CIRCUIT DESCRIPTIONS	23
5.2 2904 BOARD TRIMS	23
5.3 2904 BOARD SCHEMATICS (WITH TYPICAL VOLTAGES)	24
5.4 2904 BOARD LAYOUT	25
6. PARTS LIST	26
7. REVISIONS	27

ARP INSTRUMENTS, INC.  
320 Needham Street,  
Newton, Mass. 02164  
617 965-9700



# SECTION 1

## 2900

### Introduction

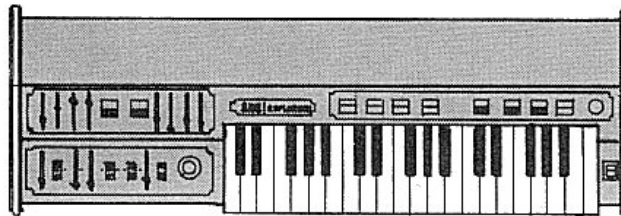

#### 1.1 DESCRIPTION

The Explorer I combines the flexibility of a variable performance synthesizer with the ease of operation of preset models. Trumpet, clarinet, reed and noise effects are produced individually or simultaneously in any of four pitch ranges. The ADSR envelope generator and the Voltage Controlled Filter can be switched into a manual mode to provide an infinite variety of sounds. Effects include a pitch bend control which doubles as an up and down one octave transpose, bender which causes a chirp when a key is depressed, automatic repeat, vibrato depth and speed controls, vibrato delay and variable portamento for sliding from one note to another.

#### 1.2 SPECIFICATIONS

*Oscillator Waveforms:* Sawtooth, Square, Narrow Pulse, Modulated-Width pulse, and any combinations.

*Noise Generator:* Pink Noise Source.

*Pitch Range:* 16' (Bass), 8' (Tenor), 4' (Alto), 2' (Soprano), and any combinations. Pitch Bend control adds 32' Contrabass.

*Voltage Controlled Filter:* Preset or Manual control. With adjustable Resonance. 24dB/octave rolloff.

*Envelope Generator:* Preset or manual control. Completely adjustable Attack, Decay, Sustain, and Release functions.

*Volume:* Controls both high and low level outputs.

*Tuning:* Concert pitch, adjustable  $\pm \frac{1}{2}$  octave.

*Repeat Switch:* Selects continuous repeat or keyboard triggered repeat.

*LFO Speed:* Determines speed of vibrato, tremolo, and repeat.

*Vibrato Depth:* From zero to  $\pm 1$  octave.

*Vibrato Delay:* Short delay, then vibrato fades in naturally for realistic and expressive playing.

*Bender:* Puts a "chirp" at the beginning of each note.

*Portamento:* Lets you slide from note to note.

*Pitch Bend:* Bends notes up to one octave sharp or flat. With center "dead" zone for easy tuning. Can also be used to extend tuning range up to an extra octave beyond normal.

#### 1.3 SIGNAL FLOW

The Explorer I has one voltage controlled sawtooth oscillator which drives a four stage frequency divider to derive four pitch ranges. Summation of the sawtooth wave with the subsequent divisions result in the generation of square, sawtooth, and pulse waves in the 2', 4', 8', and 16' pitch ranges. The output of this waveshaping circuit is applied to the audio inputs of the voltage controlled filter (VCF). The output of the VCF is connected to the voltage controlled amplifier (VCA) which is connected to the final output jack.

The keyboard controlling functions consist of a control voltage memory which supplies a one volt per octave voltage to the voltage controlled oscillator (VCO) and to the VCF. The keyboard also generates three gate signals which 1) resets the low frequency oscillator on key depressions (vibrato osc.), 2) controls the vibrato delay circuit, and 3) initiates the ADSR envelope generator. The ADSR supplies a negative going control voltage to the VCF to vary the filter cutoff and also to the VCA to control the amplifier gain.

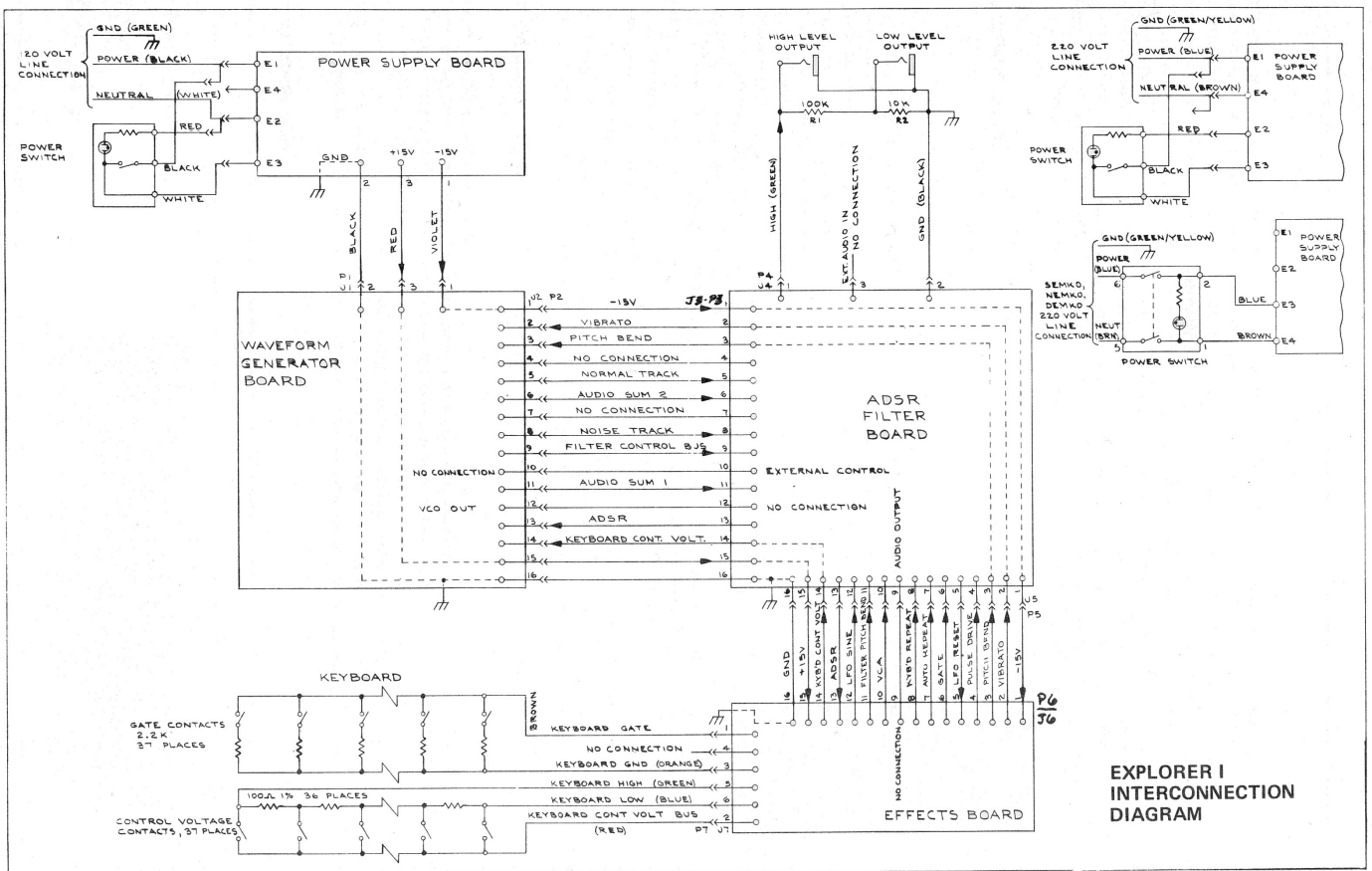

**EXPLORER I INTERCONNECTION DIAGRAM**

# SECTION 2

## 2901 BOARD

### Special Effects

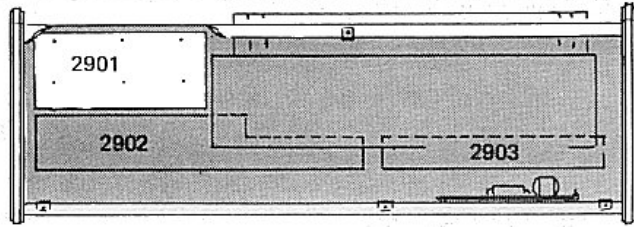

#### 2.1 2901 CIRCUIT DESCRIPTIONS

##### 2.1.1 KEYBOARD CURRENT SOURCE

The Keyboard Current Source supplies a constant current through 36 100 ohm resistors connected in series. These resistors are a voltage divider supplying specific voltages for each key on the keyboard. The top end of the resistor chain is connected to J7-5 and the low end to J7-6. The current source supplies a three volt drop across the entire resistor chain. This allows for a one volt per octave control voltage which is fed to the Control Voltage Memory circuitry via the KYBD CV bus.

##### 2.1.2 KEYBOARD CONTROL VOLTAGE MEMORY

The Keyboard Control Voltage Memory circuit samples the control voltage on a key depression and stores that voltage until a different key is depressed. The control voltage on J7-2 charges up the memory capacitor (C2) through Q2. Q2 is turned on by the Gate Generator through CR4. Q3 and Z1A are an FET op amp follower with a high input impedance to buffer the voltage on C2. The Keyboard Control voltage output is supplied to the Voltage Controlled Oscillator (VCO) and Voltage Controlled Filter (VCF) via P5-14.

##### 2.1.3 GATE CIRCUIT

Each gate contact on the keyboard is connected to a 2.2K ohm resistor to ground. When a key is depressed, the Gate Generator produces three different gate signals:

SIGNAL:	KEY UP	KEY DOWN
Pulse Drive	+15 volts	+10 volts
CV Memory Gate	-15 volts	+15 volts
Gate Output	-15 volts	0 volts

The Pulse Drive and the Gate output signals are supplied to the ADSR envelope generator via P5-6 and P5-4. The KYBD Memory gate signal updates the KYBD Memory circuit and also drives the Vibrato Delay circuit.

##### 2.1.4 VOLUME CONTROL

The Volume Control attenuates the negative going ADSR voltage from J6-13. The Volume Control output is connected to the VCA control input via J6-10.

##### 2.1.5 BENDER CIRCUIT

C7 differentiates the ADSR voltage on J6-13 and CR11 clips the positive portion of the signal. The resulting negative dip in voltage occurs on each key depression and is supplied to the control input of the oscillator through CR12 and R33.

##### 2.1.6 PITCH BEND CIRCUIT

The Pitch Bend Circuit supplies current to the control input of the voltage controlled oscillator to drive its frequency up or down. CR7 and CR8 create a 'dead zone' when the pitch bend control is centered. In this position, the frequency of the oscillator is not affected. R24 is a calibration trimmer which sets the range of the Pitch Bend control to up and down exactly one octave. The uncalibrated output on J6-11 is connected to the control input.

##### 2.1.7 LOW FREQUENCY OSCILLATOR (LFO)

The LFO produces a triangle and a square wave output in a frequency range from about .1 HZ to 25 HZ. Z2A and C3 are an integrator which charges from current passing through R17. Z2B is a hysteretic switch whose output switches from -15 volts to +15 volts when the output of Z2A reaches +5 volts. This then reverses the direction of current through R17 and the rate control (R18) and thus the direction of integration at the output of Z2A. When the output of Z2A reaches -5 volts, the output of Z2B switches to -15 volts and the cycle repeats. An LFO reset pulse is supplied from the ADSR circuit through P5-5 every time a key is depressed. Q4 is turned on momentarily by the LFO reset trigger and discharges the integrating capacitor (C3) thus resetting the LFO output to zero.

**CIRCUIT DESCRIPTIONS (CONTINUED)**

**2.1.8 VIBRATO DELAY AND WAVESHAPING**

The Vibrato Delay and Waveshaping Circuit provides two functions: (1) transforms the LFO triangle waveform into a rough sinewave; (2) delays the vibrato approximately 600 milliseconds after initial key depression. The Wave Shaping circuit receives a triangle wave from the LFO through R20. R20 and R21 attenuate the triangle wave and CR5 or CR6 (depending on the waveform polarity) rounds off the waveform by soft limiting. This results in a low voltage sine wave which is fed to the 2902 board directly through J6-12

and through the Vibrato Depth control (R22) and J6-2.

The Vibrato Delay circuit shuts off the LFO sine wave output until a short time after a key is depressed. When no keys are depressed, -15 volts is supplied from the Gate Generator circuit which reverse biases CR9. When the vibrato delay switch (S3A) is on, CR10 is then forward biased which charges C6 to a minus voltage and shuts Q5. When a key is depressed, the Gate Generator circuit supplies +15 volts through CR9 which reverse biases CR10. C6 then discharges through R30 and Q5 begins to turn on. R31 sets the charge voltage of C6 and therefore sets the delay time.

**2.2 2901 BOARD TRIMS**

REF. NO.	TRIMMER	TRIM PROCEDURE
R24 ⊗	PITCH BEND CAL.	<ol style="list-style-type: none"> <li>1. Pin low 'C' on the keyboard. Select 4" pitch range and turn on 'Hollow' waveform.</li> <li>2. Put the Pitch Bend control in the CENTER position.</li> <li>3. Using the TUNE control on the front panel, tune the output of the Explorer to a frequency standard such as a strobe tuner or frequency counter.</li> <li>4. Put the Pitch Bend control in the fully CLOCKWISE position.</li> <li>5. Using the 'Pitch Bend Calibrate' trimmer (R24), adjust the output of the Explorer to exactly one octave higher than step 3.</li> </ol>
R31 ⊗	VIBRATO DELAY	<ol style="list-style-type: none"> <li>1. Put the Vibrato Depth slider ¼ up and the Vibrato Speed slider ¾ up.</li> <li>2. Turn the Vibrato Delay switch ON.</li> <li>3. Adjust trimmer R31 for approximately 600 millisecond vibrato delay after initial key depression (or to taste).</li> </ol>

**2.3 2901 BOARD TEST POINTS**

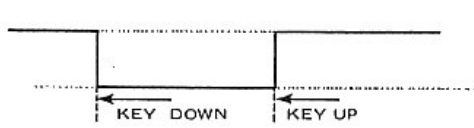
PIN NO.	FUNCTION	SPECIFICATIONS	FROM/TO
J7-1 J6-4	PULSE DRIVE (GATE BUS)		To Gate Generator Circuit and ADSR on 2902 board
J7-2	KYBD CV BUS	A. Low 'C' on the keyboard HELD..... 0 volts B. High 'C' on the keyboard HELD..... +3 volts	To Control Voltage Memory Circuit
J7-5	KYBD CURRENT SOURCE	A. No keys on the keyboard depressed..... +3 volts B. Both high 'C' and low 'C' depressed..... 0 volts	To top end of resistor chain on keyboard
J7-6	KYBD RESISTOR CHAIN	All conditions..... 0 volts	From low end of resistor chain on the keyboard

PIN NO.	FUNCTION	SPECIFICATIONS	FROM/TO
J6-2	VIBRATO	<p>Vibrato depth control maximum Vibrato speed control maximum</p> <p>+0.5 volts 0 volts -0.5 volts 40 milliseconds (typical)</p>	To VCO on 2903 board
J6-6	GATE OUTPUT	<p>0 volts -15 volts KEY DOWN KEY UP</p>	To ADSR on 2902 board
J6-7	AUTO REPEAT	<p>+15 volts 0 volts -15 volts KEY DOWN REPEAT OFF AUTO REPEAT KYBD REPEAT (KEY HELD)</p>	To ADSR on 2902 board
J6-8	KYBD REPEAT	<p>A. Repeat switch in OFF position..... 0 volts +15 volts</p> <p>0 volts -15 volts B. KYBD RPT. ON C. AUTO RPT. ON</p>	To ADSR on 2902 board
J6-10	VCA (VOLUME CONTROL OUTPUT)	<p>Put ADSR in 'Preset' mode.</p> <p>0 volts -0.7 volts KEY DOWN KEY UP</p>	To VCA control input on 2902 board
J6-11	FILTER PITCH BEND OUTPUT	<p>A. Pitch Bend control centered..... 0 volts B. Pitch Bend control fully CLOCKWISE..... +14 volts C. Pitch Bend control fully COUNTER CLOCKWISE.. -14 volts</p>	To VCF on 2902 board
J6-12	LFO SINE WAVE OUTPUT	<p>Turn on 'Vibrato Delay' switch, put 'LFO Speed' slider in the maximum position.</p> <p>+0.5 volts -0.5 volts 600 MILLISECONDS (TYPICAL)</p>	To VCF on 2902 board
J6-14	KYBD CV OUTPUT	<p>A. 'C1' (low C) depressed..... 0.0 volts B. 'C2' depressed..... +1.0 volts C. 'C3' depressed..... +2.0 volts D. 'C4' depressed..... +3.0 volts</p>	To VCO and VCF (2902 & 2903 board)

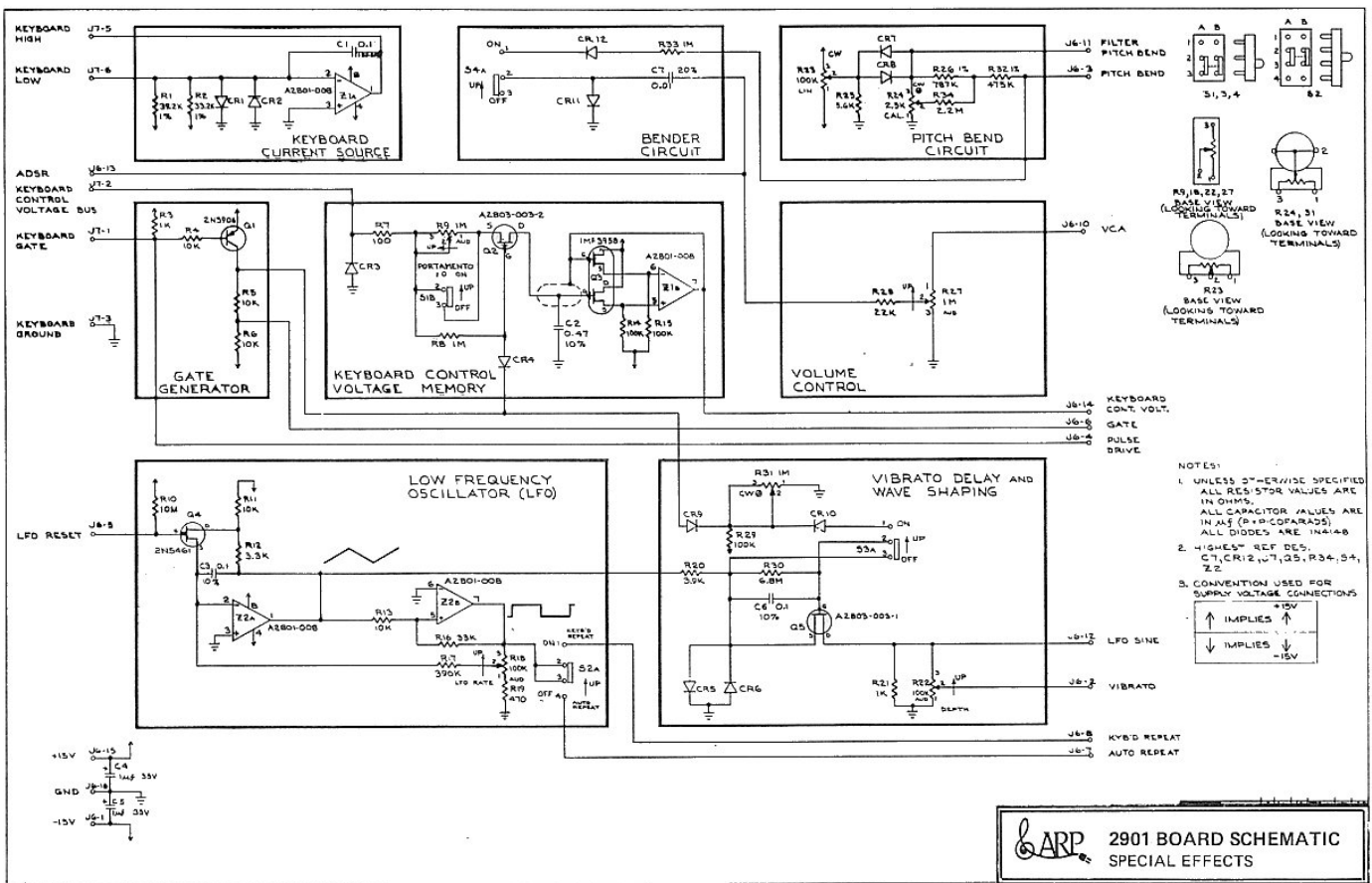

**ARP** 2901 BOARD SCHEMATIC  
SPECIAL EFFECTS

2901 BOARD LAYOUT  
FOIL SIDE VIEW

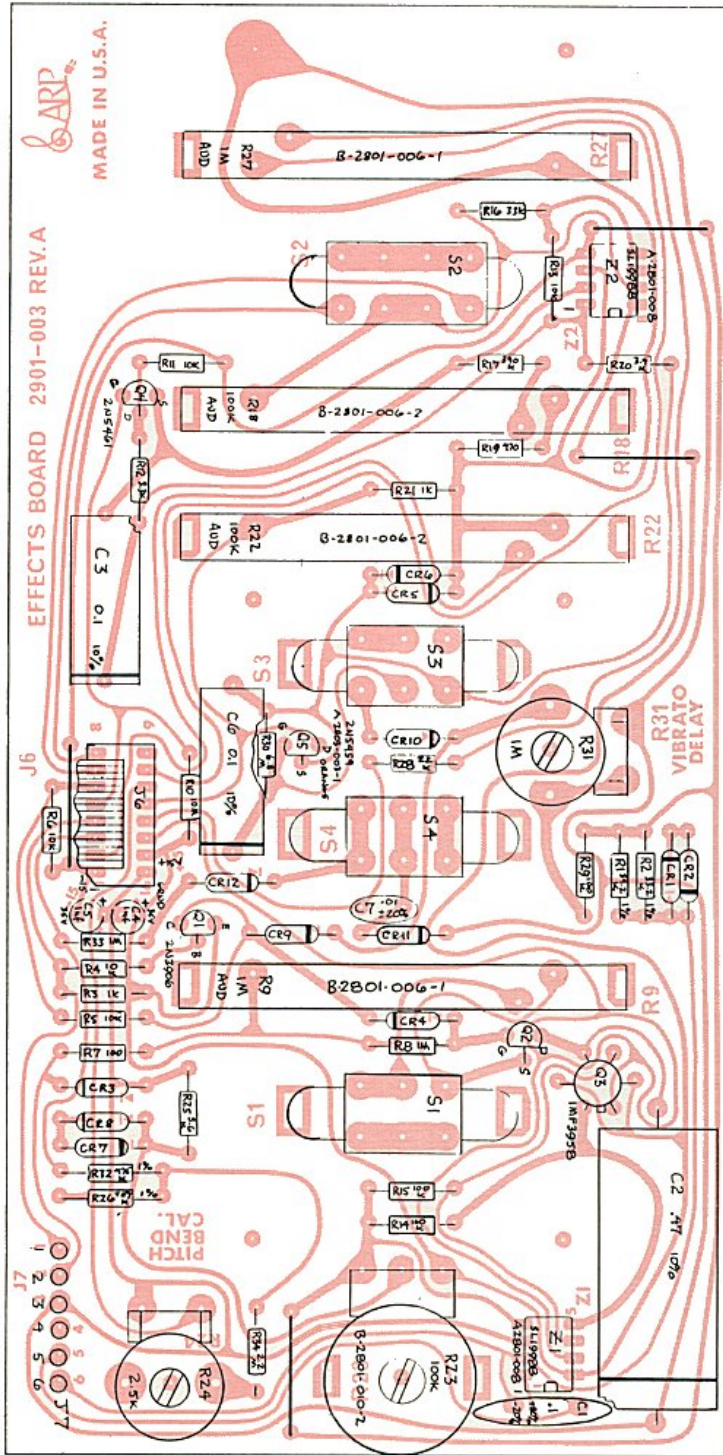

# SECTION 3

## 2902 BOARD

### ADSR - VCF - VCA

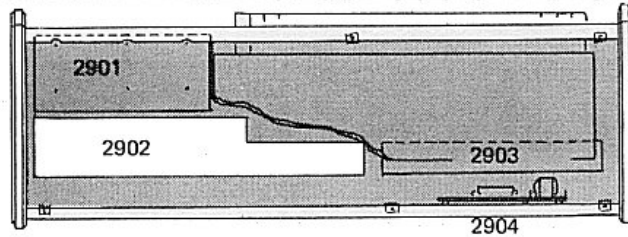

### 3.1 2902 CIRCUIT DESCRIPTIONS

#### 3.1.1 ADSR CIRCUIT

The ADSR envelope generator circuit provides a negative going DC voltage to control the VCF cutoff and the VCA gain.

**ATTACK:** When a key is depressed, the gate voltage on J5-6 rises from -15 volts to 0 volts and the pulse drive on J5-4 drops to +10 volts. Q3, C5, and Z2A prevent Z2B from changing state for about 10 milliseconds. The delay pulse on Z2A pin 3 is used for the LFO reset pulse through C9. When the output of Z2B changes from high to low, -15 volts is applied through CR8 and R41 to the noninverting input of follower Z3. During the attack mode, Q7 is off, and R40 is disconnected from ground. Z3 directly follows the voltage on pin 3 and applies -15 volts through CR10, R59 (or R58) to charge integrating capacitor C10 down.

**DECAY AND SUSTAIN:** Z4 is a buffer amplifier following the voltage on capacitor C10. The output of C4 is applied to Q4 through R2 and CR6. As the ADSR voltage approaches -13 volts, Q4 begins to turn off and R35 lowers the voltage on pin 13 of Z2C. Z2C and Z2D is a bistable latch. When pin 13 falls below the threshold of the nand gate (about -7.5 volts) the output of Z2D changes from high to low applying -15 volts from pin 10 of Z2 through CR7, R37, and CR6 thus holding Q4 off. Q7 now turns on and the voltage divider consisting of R41 and R40 (or R43 and R42) establishes the Sustain Level. CR10 is now reversed biased and capacitor C10 discharges through R57 (or R56) and CR9 to the level at Z3 pin 3.

**RELEASE:** When the gate voltage is removed, Q5 turns on which turns on Q6. The remaining voltage on capacitor C10 discharges through R55 (or R54) and Q6 to ground. The output of Z4 is applied to the input of follower Z3 through R44 thereby preventing the sustain and decay charge paths from affecting the release time.

The chart on the right shows test points in the ADSR. Refer to the schematic on page 14 for the location of the test points.

NOTE: USE X10 PROBE WITH OSCILLOSCOPE

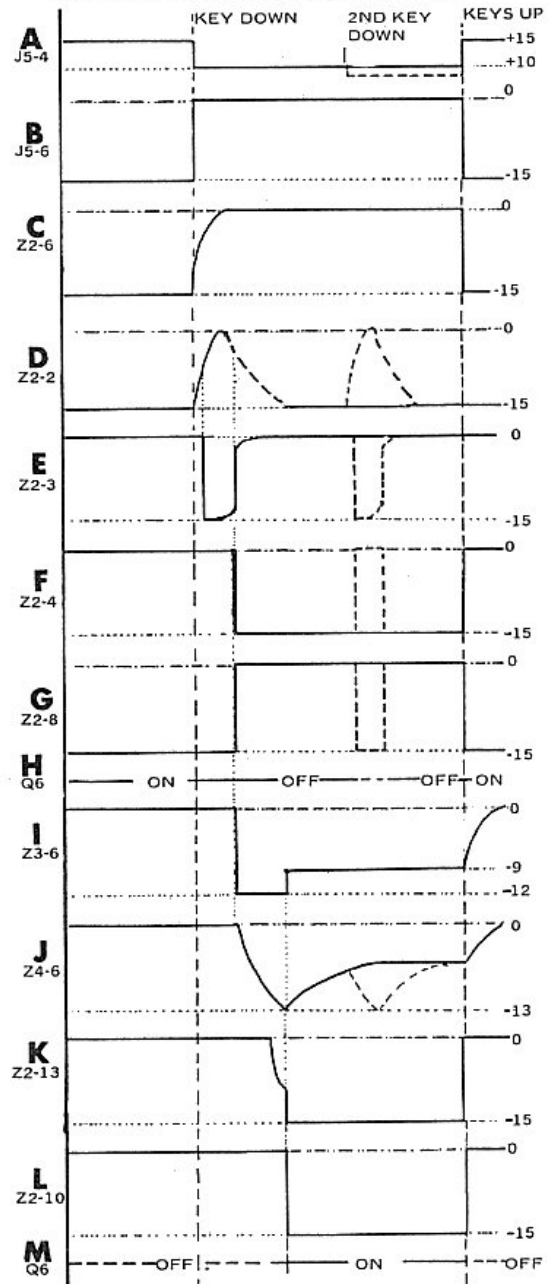

CIRCUIT DESCRIPTIONS (CONTINUED)

3.1.2 THE VOLTAGE CONTROLLED FILTER (VCF)

The VCF is a 24db/octave lowpass filter. Pins 1 and 2 of the 4034 module are audio summing inputs and pin 10 is the audio output. Pin 4 sums all control voltages to vary the filter cutoff frequency; negative control voltages applied to this point raise the cutoff frequency. The Keyboard Control Voltage, Pitchbend voltage, LFO, Siné Wave, and Filter Control voltages are summed together and inverted by ZIB. The "Track" trimmer (R30) attenuates control voltages from ZIB so that the VCF has approximately a one volt per octave response. The ADSR voltage, which is already negative, is applied directly to the control input of the filter through R33 (or R31) and R34. The "Offset" trimmer (R49) sets the initial filter frequency cutoff point and the Control Rejection trim-

mer (R53) minimizes the effect of control voltage changes on the output of the 4034. The resonance feedback path is through R64 (or R62) and R63 to pin 2 of the 4034 module.

3.1.3 THE VOLTAGE CONTROLLED AMPLIFIER (VCA)

The VCA attenuates signals from the output of the VCF. The gain of the VCA is determined by the amount of negative current supplied to the differential pair in the transistor array Z5. The ADSR output is connected to the control input (pin 3) via the Volume slider on the 2901 board and J5-10. The control rejection trimmer (R15) minimizes the effect of control voltage charges on the output of the VCA. CR1, CR2 and R1 provide output protection to prevent external voltages from entering the 2900 circuits through the output jack.

3.2 2902 BOARD TRIMS

REF. NO.	TRIMMER	TRIM PROCEDURE
R30 ⊗	VCF TRACK	<ol style="list-style-type: none"> <li>1. Put the ADSR in the 'preset' mode.</li> <li>2. Put the VCF in the 'manual' mode.</li> <li>3. Put the VCF resonance slider up fully and put the ADSR and LFO to the VCF fully down.</li> <li>4. Pin low 'C' on the keyboard and turn on the 'Noise' waveform.</li> <li>5. Adjust the VCF FREQUENCY slider so that the output of the Explorer produces a 130 Hz. pitch or 'C' on a strobe tuner when a key is depressed.</li> <li>6. Pin high 'C' on the keyboard.</li> <li>7. Adjust R30 so that the output of the Explorer is 1040 Hz. or 'C' three octaves higher on the strobe tuner when a key is depressed.</li> <li>8. Repeat steps 5 through 7 until the output of the explorer is in tune on low 'C' and on high 'C'.</li> </ol>
R49 ⊗	VCF OFFSET (CALIBRATE)	<ol style="list-style-type: none"> <li>1. Put the ADSR and The VCF in the 'preset' mode.</li> <li>2. Put the ADSR to VCF slider in the midposition and the LFO to VCF slider fully down.</li> <li>3. Select the 'Hollow' waveform and the 4' pitch range.</li> <li>4. Adjust R49 for the best clarinet sound when a key is depressed.</li> </ol>
R15 ⊗	VCA CONTROL REJECT	<ol style="list-style-type: none"> <li>1. Turn off all waveform and pitch range switches.</li> <li>2. Put the VCF in the 'preset' mode and put the ADSR and LFO sliders to the VCF fully down.</li> <li>3. Put the ADSR in the manual mode; attack down, decay ¼, sustain down and release down.</li> <li>4. Adjust R53 for minimum 'thump' when a key is depressed.</li> </ol>

REF. NO.	TRIMMER	TRIM PROCEDURE
R53 	VCF CONTROL REJECT	<p><i>NOTE: THE VCA CONTROL REJECT TRIMMER (R15) MUST BE ADJUSTED BEFORE THE VCF CONTROL REJECT TRIMMER (R53).</i></p> <ol style="list-style-type: none"> <li>1. Turn off all waveform and pitch range switches.</li> <li>2. Put the VCF in the 'preset' mode.</li> <li>3. Put the ADSR in the 'manual' mode; attack down, decay <math>\frac{1}{4}</math>, sustain down and release down.</li> <li>4. Raise the ADSR slider to the VCF fully and lower the LFO slider to the VCF.</li> <li>5. Adjust R53 for minimum 'thump' when a key is depressed.</li> </ol>

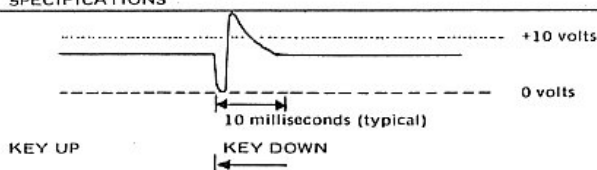
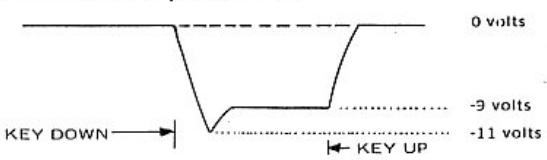
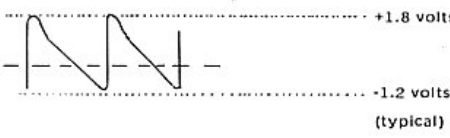
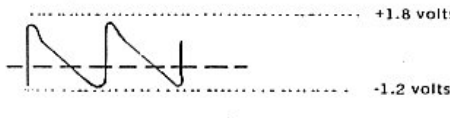
3.3 2902 BOARD TEST POINTS			
PIN. NO.	FUNCTION	SPECIFICATIONS	FROM/TO
J5-5	LFO RESET PULSE	 <p>KEY UP</p> <p>KEY DOWN</p> <p>10 milliseconds (typical)</p> <p>+10 volts</p> <p>0 volts</p>	To LFO on 2901 board.
J3-13 J5-13	ADSR OUTPUT	<p>Put the ADSR in the 'preset' mode.</p>  <p>KEY DOWN</p> <p>KEY UP</p> <p>0 volts</p> <p>-9 volts</p> <p>-11 volts</p>	To the VCF on 2902 board and volume control on 2901 board.
4034 PIN 10	VCF OUTPUT	<p>Turn on 4' pitch range and sawtooth waveform. Put the ADSR and the VCF in the 'preset' mode. Pin low 'C' on the keyboard.</p>  <p>+1.8 volts</p> <p>-1.2 volts (typical)</p>	To VCA control audio input on 2902 board.
J5-9 J4-1	2900 OUTPUT	<p>Turn on 4' pitch range and sawtooth waveform. Put the ADSR and the VCF in the 'preset' mode. Pin low 'C' on the keyboard.</p>  <p>+1.8 volts</p> <p>-1.2 volts</p>	To output jack.



2902 BOARD LAYOUT  
FOIL SIDE VIEW

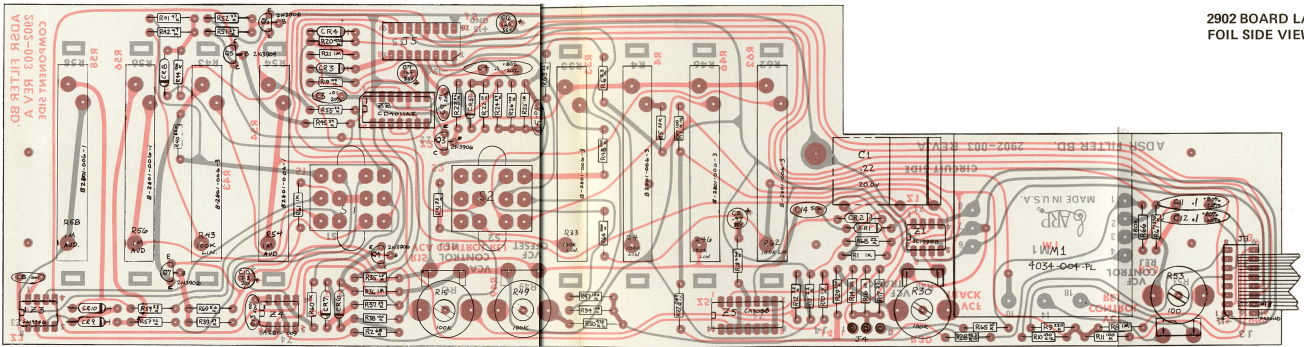

# SECTION 4

## 2903 BOARD

### Waveform Generator

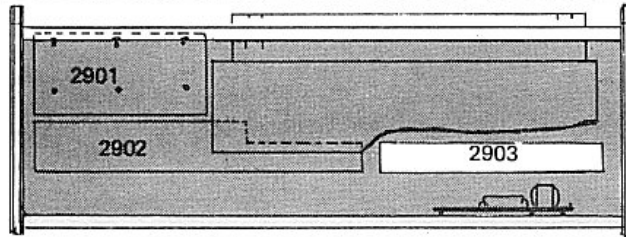

#### 4.1 2903 CIRCUIT DESCRIPTIONS

##### 4.1.1 THE VOLTAGE CONTROLLED OSCILLATOR

The Voltage Controlled Oscillator provides a 10 volt peak to peak positive going sawtooth wave to the Frequency Divider and Waveshaping Circuit. The Keyboard Control Voltage, Pitch Bend Voltage and LFO Sine wave are summed together on pin 2 of the 4027-1 module. The volts per octave trimmer (R42) sets the sensitivity of the VCO so that the frequency exactly doubles for each volt applied to the control input. R41 sets the initial frequency of the VCO.

##### 4.1.2 FILTER CONTROLS

The Filter Controls supply voltage to the control input of the VCF to raise the cutoff frequency when the higher pitch ranges are used. The Keyboard Control Voltage is connected to the VCF control input through the Noise switch (S9A) which selects either two volts per octave tracking or one volt per octave tracking.

##### 4.1.3 NOISE GENERATOR

The noise generator circuit produces a 25 volt peak to peak white noise signal which is applied to Audio summing point 1 (J2-II) when the Noise switch is on. The noise is obtained by amplifying a reversed biased transistor junction (Q1) in avalanche breakdown. Q1 is a transistor selected for optimum avalanche characteristics and therefore has a good noise producing capability. Q2 is a buffer and Z4 amplifies and clips the noise signal.

##### 4.1.4 FREQUENCY DIVIDER AND WAVESHAPING

The Frequency Divider and Waveshaping circuitry has two functions: (A) it generates waveshapes at specified frequency divisions (2', 4', 8' and 16') and (B) channels the selected waveform to one of two VCF audio summing points on the 2902 board. The four waveforms produced by the Explorer are: squarewave (hollow), sawtooth (brass), pulse (reed), and Variable pulse (fuzz).

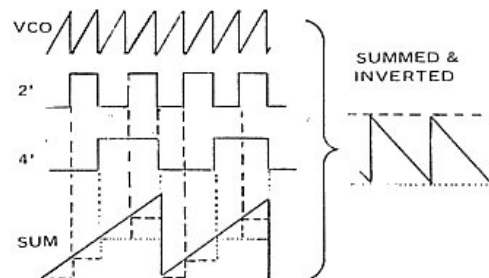

**SQUAREWAVE:** The squarewave is obtained by differentiating the falling edge of the sawtooth from the 4027-1 oscillator to trigger a CMOS 4-stage frequency divider (Z1). Q4 is in common base configuration for impedance matching. The frequency divider has four outputs, each supplying half the frequency of the preceding stage. Each division of the squarewave is channeled to the Audio sum 2 output point (J2-6) via the Pitch Range and Hollow switches.

**SAWTOOTH:** When the sawtooth waveform is selected, the output of the sawtooth oscillator and the outputs of the squarewave divider are summed together on the inverting inputs of the mixer op amps Z2 and Z3. The outputs of each mixer are negative going sawtooth waves at the frequency of the lowest squarewave used. As long as the sawtooth waves and the squarewaves on the input of the mixers are positive, the output will be negative, thus forward biasing CRI-4 to provide a feedback path and setting the gain of the op amp.

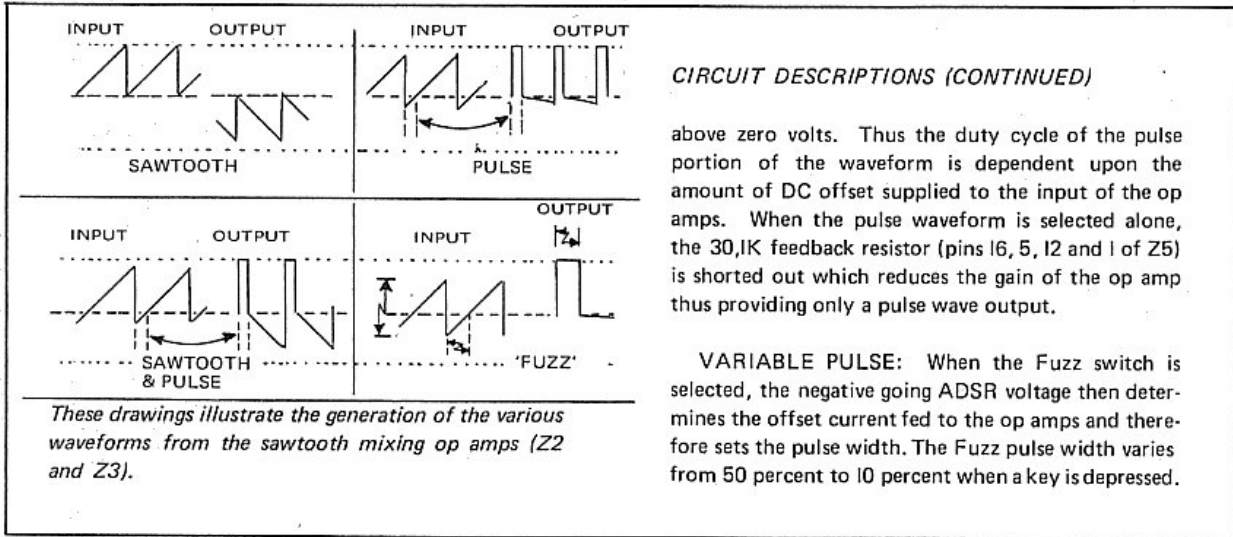

**PULSE:** When the pulse wave is selected, a DC offset is applied from Q3 to the inputs of op amps Z2 and Z3. The output of the op amps will then be above zero volts for a portion of the sawtooth waveform cycle. When this occurs, the feedback diodes (CRI-CR4) are reversed biased and the op amps work as comparators. When the waveform falls below zero volts on the input, the output of the op amp rises to +15 volts and remains there until the voltage on the input rises above zero volts. If a sawtooth is also selected, the op amp conducts the sawtooth waveform normally when the input voltage of the op amp is



4.2 2903 BOARD TRIMS		
REF. NO.	TRIMMER	TRIM PROCEDURE
R41 	VCO CALIBRATE	<ol style="list-style-type: none"> <li>1. Turn on the 4' Pitch Range switch.</li> <li>2. Put the Pitch Bend control in the center position.</li> <li>3. Turn on the Square waveform.</li> <li>4. Put the ADSR and the VCF in the 'preset' mode.</li> <li>5. Put the VCO fine tune control on the front panel in the center position.</li> <li>6. Adjust R41 so that the output of the Explorer is about 130 Hz. when low 'C' is depressed.</li> </ol>
R42 	VCO V/OCT (VOLTS PER OCTAVE)	<ol style="list-style-type: none"> <li>1. Turn on the 4' Pitch Range switch.</li> <li>2. Put the Pitch Bend control in the center position.</li> <li>3. Turn on the Square waveform.</li> <li>4. Put the ADSR and the VCF in the 'preset' mode.</li> <li>5. Pin low 'C'.</li> <li>6. Using the VCO Fine Tune control on the front panel, adjust the output of the Explorer for a frequency of 130Hz. or a low 'C' on a strobe tuner.</li> <li>7. Pin high 'C'.</li> <li>8. Using trimmer R42, adjust the output of the Explorer to exactly 1040 Hz. or 'C' exactly three octaves higher than step 6.</li> <li>9. Repeat steps 5 through 8 until the frequency of the Explorer is correct on low 'C' and on high 'C'.</li> </ol>

4.3 2903 BOARD TEST POINTS			
PIN NO.	FUNCTION	SPECIFICATIONS	FROM/TO
J2-5	NORMAL TRACK	A. Noise switch off, low 'C' depressed..... 0 volts B. Noise switch off, high 'C' depressed..... +3 volts C. Noise switch on.....0 volts with 2 volt peak to peak noise	To VCF control input, 2902 board

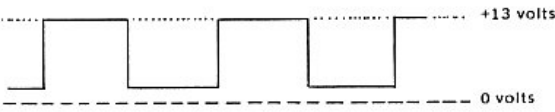
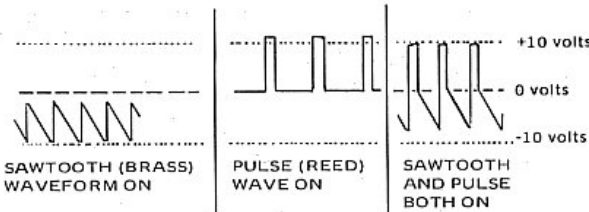
PIN NO.	FUNCTION	SPECIFICATIONS	FROM/TO
J2-6	AUDIO SUM 2	Turn on 4' pitch range and Square waveform 	To VCF audio summing input 2
J2-8	NOISE TRACK	A. Noise switch off..... .3 volt peak to peak noise signal B. Noise switch on, low 'C' depressed..... 0 volts C. Noise switch on, high 'C' depressed..... +3 volts	To VCF control input, 2902 board
J2-9	FILTER CONTROL	A. All Pitch Range switches off..... 0 volts B. 16' Pitch Range switch on only..... 0 volts C. 8' Pitch Range switch on only..... +5 volts D. 4' Pitch Range switch on only..... +10 volts E. 2' Pitch Range switch on only..... +15 volts	To VCF control input, 2902 board
J2-11	AUDIO SUM 1	TURN ON 4' PITCH RANGE SWITCH 	To VCF audio summing input 1

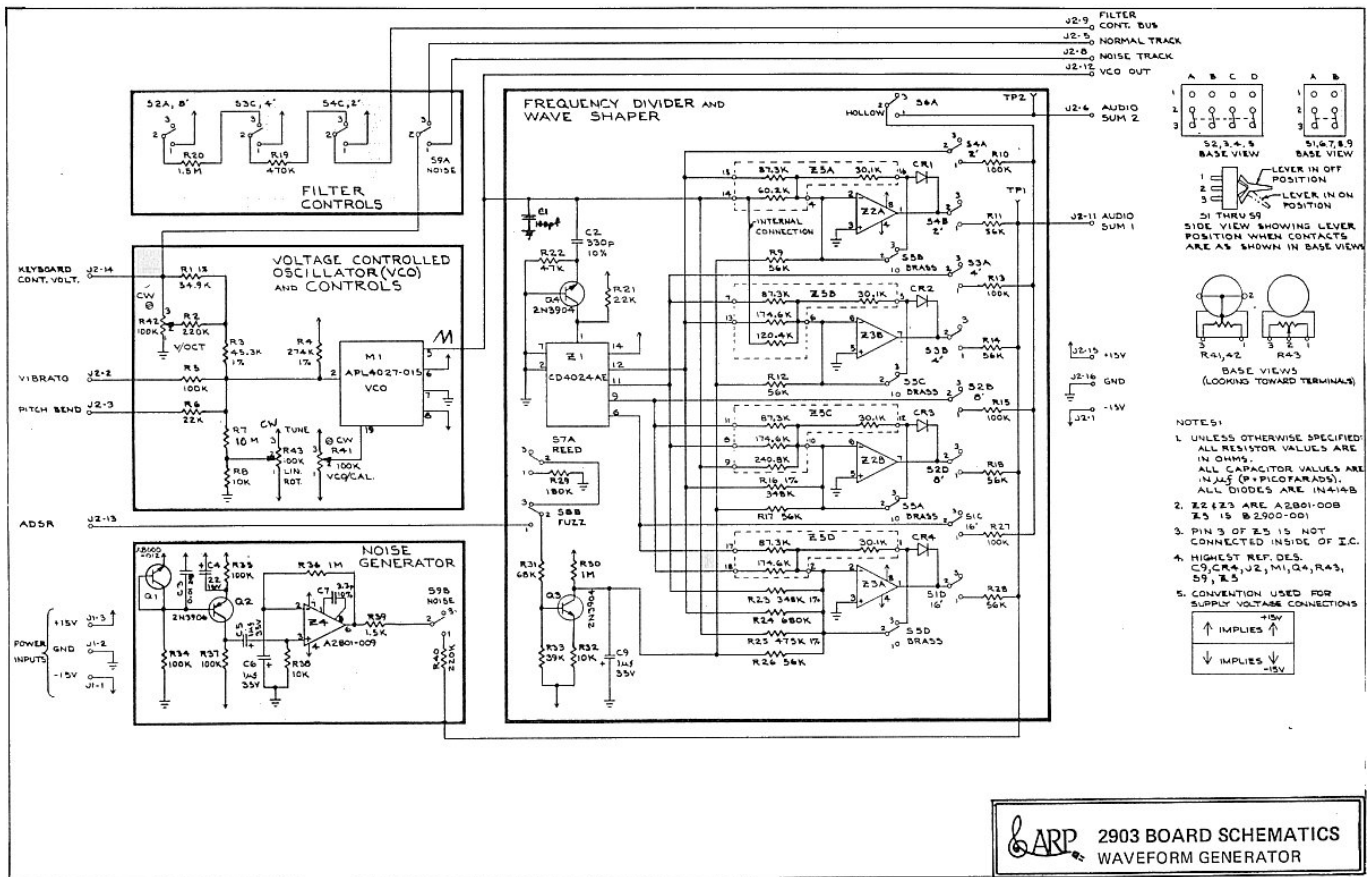

**LARP** 2903 BOARD SCHEMATICS  
WAVEFORM GENERATOR

2903 BOARD LAYOUT  
FOIL SIDE VIEW

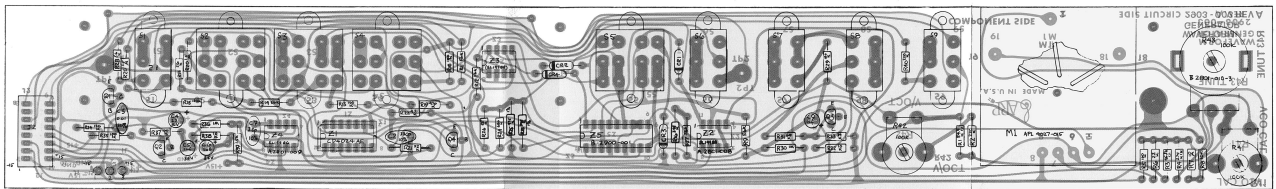

# SECTION 5

## 2904 BOARD

### Power Supply

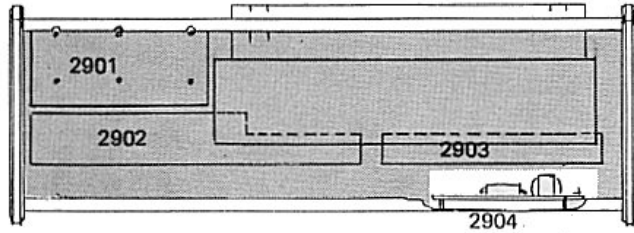

#### 5.1 CIRCUIT DESCRIPTIONS

##### 5.1.1 VOLTAGE SOURCE

CRI-4 is a full wave bridge rectifier supplying about plus and minus 28.5 volts to the regulating circuitry. C1 and C5 filter out ripple on the supply lines.

##### 5.1.2 +15 VOLT SUPPLY

Z1 contains a voltage reference which supplies about 7.4 volts to pin 6 of Z1. This fixed voltage is connected through pin 5 to the non-inverting input of an op amp. The output of the op amp is connected to an emitter follower, also located inside Z1, which controls the current amplifier. The power supply normally delivers +15 volts to the output; if the voltage should change, the voltage at the junction of R3 and R6 will also change. This point is connected to the inverting input of the op amp through pin 4 of Z1. If the voltage at this point should drop, the output of the op amp will rise, turning on the emitter follower and the current amplifier, thus increasing the output voltage. Similarly, if the voltage at the resistor junction should increase, the voltage on the output of the op amp will decrease which limits the current through the current amplifier and lowers the output voltage. R5 and the +15 volt trimmer sets the voltage level on the inverting input of the op amp and thus sets the output voltage of the supply.

##### 5.1.3 +15 VOLT CURRENT LIMITING

When enough current flows out of the positive power supply to cause a .7 volt drop across R2, the transistor connected to pins 2 and 3 of Z1 turns on, effectively shorting the base of the emitter follower to the output voltage of the +15 supply. Q1 in turn supplies less current to the output.

##### 5.1.4 -15 VOLT SUPPLY

The -15 volt supply derives its regulation from the +15 volt supply through R8. When the output of the -15 volt supply is at the correct voltage, the junction of R8 and R12 is zero volts. The base of Q2 is referenced to zero volts through R9. Should the output of the supply increase, the voltage on the base of Q3 will also increase which begins to turn off Q3. Q2 conducts more current thus turning Q4 on harder. Q4 drives the current amplifier Q5 which will then conduct more current thereby lowering the output to -15 volts.

##### 5.1.5 -15 VOLT CURRENT LIMITING

When enough current is drawn from the -15 volt supply to cause a .7 volt drop across R16, Q6 turns on which applies -28 volts to the base of Q4 thus shutting Q4 and Q5 off.

#### 5.2 POWER SUPPLY TRIMS

REF. NO.	TRIMMER	TRIM PROCEDURE
R5 ⊗	+15 VOLT SET	1. Monitor the power supply's +15 volt output with a digital voltmeter. 2. Adjust R5 for exactly +15.00 volts.
R11 ⊗	-15 VOLT SET	1. Set R5 (+15 volts) first. 2. Put the digital voltmeter's ground lead on the power supply's -15 volt output and put the meter's plus lead on the power supply's ground output. 3. Adjust R11 for exactly +15.00 volts.

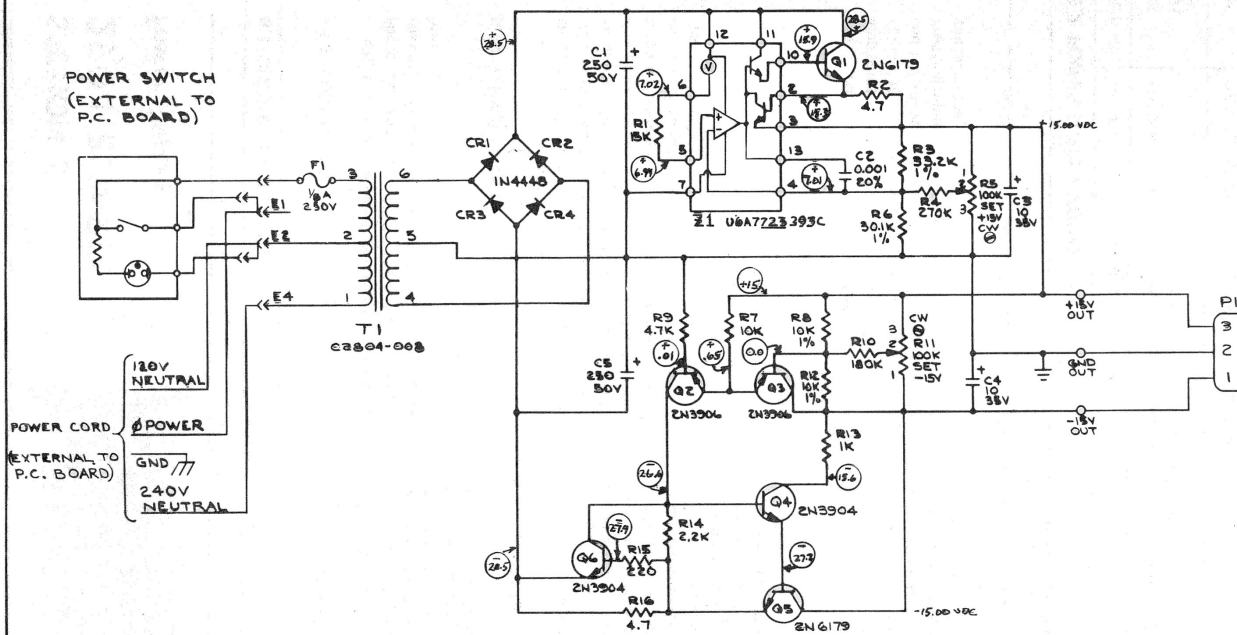

POWER SWITCH  
(EXTERNAL TO  
P.C. BOARD)

POWER CORD  
(EXTERNAL TO  
P.C. BOARD)

120V  
NEUTRAL

240V  
NEUTRAL

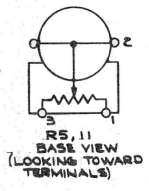

- NOTES:
- UNLESS OTHERWISE SPECIFIED:  
RESISTOR VALUES ARE IN OHMS  
CAPACITOR VALUES ARE IN  $\mu$ F (P.P.P.G.P.FARADS)
  - HIGHEST REP. DES: Q6, E1, CR4, C3, R16, E4, T1 & F1
  - (0.0) INDICATES TYPICAL VOLTAGES AS READ WITH A DV.M.

2904 BOARD LAYOUT  
COMPONENT SIDE VIEW

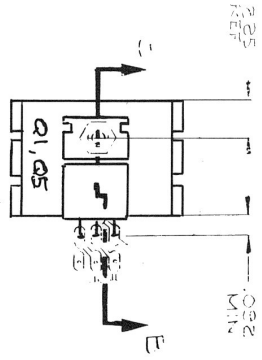
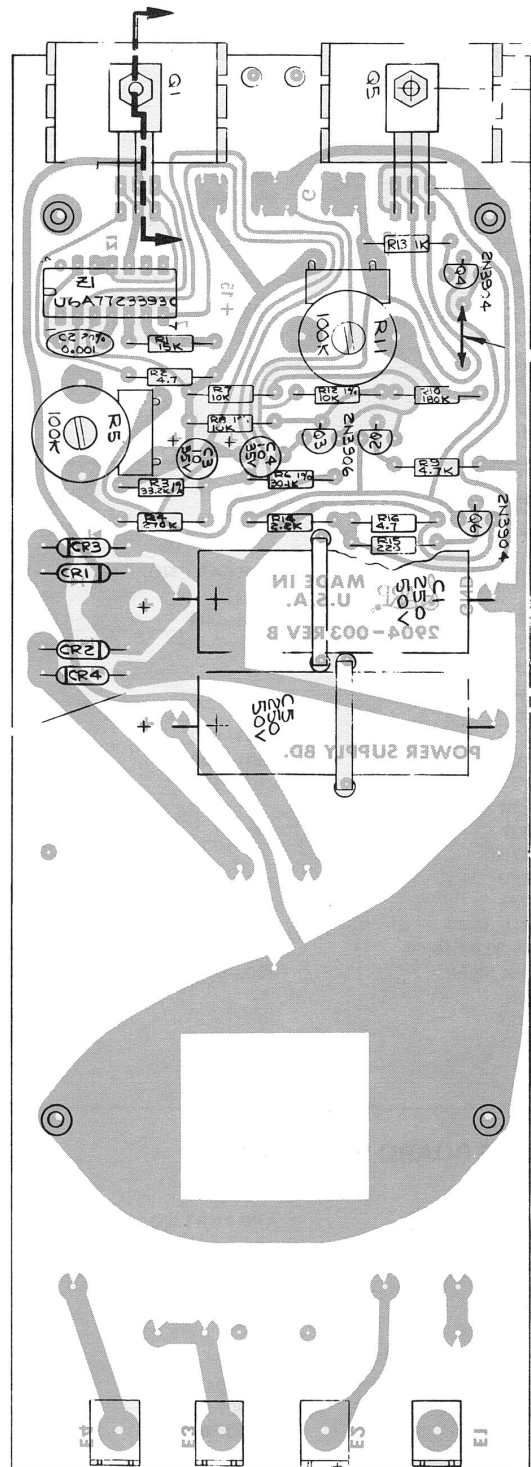

MOUNTING ALTERNATE  
TRANSISTORS 2N5298 & 2N5494

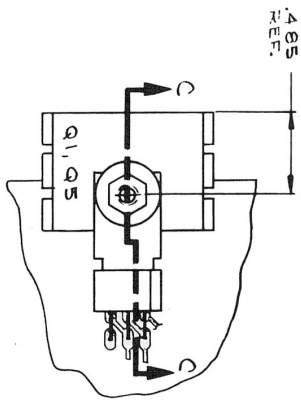

MOUNTING ALTERNATE  
TRANSISTOR D40D4

## SECTION 6 - PARTS LIST

### 2901 BOARD PARTS LIST

REFERENCE	ARP PART NO.	MFG. NO.	DESCRIPTION
CR1-12		IN4148	SIGNAL DIODE
Q4		2N5461	TRANSISTOR, FET
Q3		IMF3958	TRANSISTOR, J FET
Q1	2N3906	2N3906	TRANSISTOR, PNP
Z1, 2	2801-008	SL19988	OP AMP, TESTED 1458
Q5	2803-003-1 ORANGE	2N5459	TRANSISTOR, SELECT
Q2	2803-003-2 YELLOW	2N5459	TRANSISTOR, SELECT
R24		U201R252B	2.5K ROTARY POT
R31		U201R105B	1M ROTARY POT
R23	2801-010-2		100K ROTARY POT
R18, 22	2801-006-2		100K AUDIO SLIDEPOT
R9, 27	2801-006-1		1 MEG AUDIO SLIDEPOT
C4, 5		TAG-00-1/35-20/20	1uf CAP TANT 35V
C2		WCR1P47	.47uf CAP P CARB 100V
J6	2901-020-1		CABLE, 16 PIN, 4 INCH

### 2902 BOARD PARTS LIST

REFERENCE	ARP PART NO.	MFG. NO.	DESCRIPTION
M1	4034-004		VCF MODULE
CR1-10		IN4148	SIGNAL DIODE
Q5		2N3904	TRANSISTOR, NPN
Q3,4,6,7		2N3906	TRANSISTOR, PNP
Z5		CA3086	TRANSISTOR ARRAY, NPN
Z2	2803-002	CD4011AE	QUAD NAND GATE
Z1	2801-008	SL19988	OP AMP, TESTED 1458
Z3,4	2801-009	SL19986	OP AMP, TESTED LM301AN
R28		CC4532F	45.3K, 1/4w, 1% RESISTOR
R27		CC5492F	54.9K, 1/4w, 1% RESISTOR
R7,10		CC1003F	100K, 1/4w, 1% RESISTOR
R50		CC4753F	475K, 1/4w, 1% RESISTOR
R53		U201R101B	100 ohm ROTARY POT
R15,30,49		U201R104B	100K LINEAR ROTARY POT
R4,33,43,46,62	2801-006-3		100K LINEAR SLIDEPOT
R54,56,58	2801-006-1		1 MEG AUDIO SLIDEPOT
C2		TAG-00-47/35-20/20	.47uf CAP TANT 35V 20%
C6,7		TAG-00-1/35-20-20	1uf CAP TANT 35V 20%
C10		TAG-00-3.3620-10/10	3.3uf CAP TANT 20V, 10%
C1		225P-22492-XD3	.22uf CAP P ESTER 200V 10%

### 2903 BOARD PARTS LIST

REFERENCE	ARP PART NO.	MFG. NO.	DESCRIPTION
M1	4027-1		VCO MODULE
CR1-4		IN4148	SILICONE SIGNAL DIODE
Q3,4		2N3904	SILICONE TRANSISTOR, NPN
Q2		2N3906	SILICONE TRANSISTOR, PNP
Z1		CD4024AE (CM4024)	FREQUENCY DIVIDER
Q1	A-8000-012	2N5172 SELECT	NOISE TRANSISTOR
Z2, Z3	A-2801-008	SL19988(LM1458)	SELECT DUAL OP AMP
Z4	A-2801-009	SL19986(LM301AN)	SELECT SINGLE OP AMP

2903 BOARD PARTS LIST CONTINUED

REFERENCE	ARP PART NO.	MFG. NO.	DESCRIPTION
R3		CC4532F	45.3K, 1/4W, 1% RESISTOR
R1		CC5492F	54.9K, 1/4W, 1% RESISTOR
R4		CC2743F	274K, 1/4W, 1% RESISTOR
R16,23		CC3483F	348K, 1/4W, 1% RESISTOR
R25		CC4753F	475K, 1/4W, 1% RESISTOR
Z5	B-2900-001		CERMET RESISTOR PACK
R41,42		U201R104B	100K LIN. ROT. POT. (TRIMMER)
R43	B-2801-010-2		100K LIN. ROT. POT. (TUNE)
C5,6,9		TAG-00-1/35-20/20	1uf TANT. 35V, 20% CAPACITOR
C4		TAG-00-22/16-20/20	22uf TANT, 16V, 20% CAPACITOR
S6,7,8		02-481-0011B	DPDT BLACK ROCKER SWITCH
S1,9		02-481-0012B	DPDT WHITE ROCKER SWITCH
S5		02-481-0013B	4PDT BLACK ROCKER SWITCH
S2,3,4		02-481-0014B	4PDT WHITE ROCKER SWITCH

2904 BOARD PARTS LIST

REFERENCE	ARP PART NO.	MFG. NO.	DESCRIPTION
Q1,5		2N6179(orD40D4)	NPN POWER TRANSISTOR
Q4,Q6		2N3904	SILICONE TRANSISTOR NPN
Q2,Q3		2N3906	SILICONE TRANSISTOR, PNP
Z1		UGA7723393C(723)	+15 V REGULATOR IC.
CR1-4		IN4448	RECTIFIER DIODE, 75V, 200MA.
R8,12		CC1002F	10K, 1/4W, 1% RESISTOR
R6		CC3012F	30.1K, 1/4W, 1% RESISTOR
R3		CC3322F	33.2K, 1/4W, 1% RESISTOR
R2,R16		CB47G1	4.7ohm, 1/4W, 10% RESISTOR
R5, R11		U201R104B	100K LIN. ROT. POT. (TRIM)
C3, C4		TAG-00-10/35-50/20	10uf TANT. 35V CAPACITOR
C1,C5		B41010-250/50	250uf, ELECT. 50V, CAPACITOR
T1	C2804-008		POWER TRANSFORMER
--		MDV-1/8	SLO-BLOW FUSE, 1/8 AMP.

SECTION 7 - REVISIONS AND UPDATES



# SERVICE NOTES

SN-014

MODEL: EXPLORER      DATE: 2-20-75

SUBJECT: TROUBLESHOOTING HINTS

**PROBLEM:** The Explorer produces sound even without a key depressed. When a key is depressed and released, the pitch drifts up. The Sustain on the ADSR does not function.

**CAUSE:** One or more of the GATE CONTACTS on the keyboard assembly has lodged on the wrong side of the bus rod.

**SOLUTION:** Snap the contact back in place.



# FIELD CHANGE NOTICE

MODEL: 2900

DATE: 10-31-74

EFFECTIVITY: ALL UNITS

EST. TIME TO COMPLETE: ½ HOUR

**REASON FOR CHANGE:** To prevent the output of the ADSR from changing when the ADSR manual/preset switch is moved from the upper position to the lower position. Units requiring this change will produce sound on the output of the 2900 without depressing a key when the ADSR manual/preset switch is moved.

**MATERIAL REQUIRED:** (1) 22M ¼W resistor, (1) IN4148 silicone diode.

**PARTS DISPOSITION:** Order parts kit FCN-001 from the factory.

**DOCUMENTS AFFECTED:** EXPLORER I ADSR FILTER BOARD SCHEMATIC, D2902-001.

**DETAILS OF CHANGE:** Add the 22M resistor from pin 3 of Z3 to +15 volts, add the diode from the plus side of capacitor C10 with the cathode to the minus side of C10.

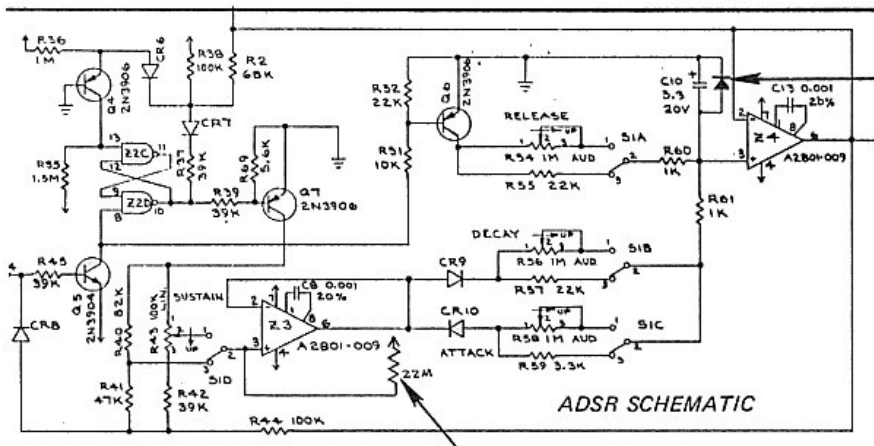

ADD IN4148 DIODE

ADD 22M ¼W RESISTOR

