

YAMAHA[®]

**AUTHORIZED
PRODUCT MANUAL**

SY22

MUSIC SYNTHESIZER

YAMAHA

MUSIC SYNTHESIZER

SY22

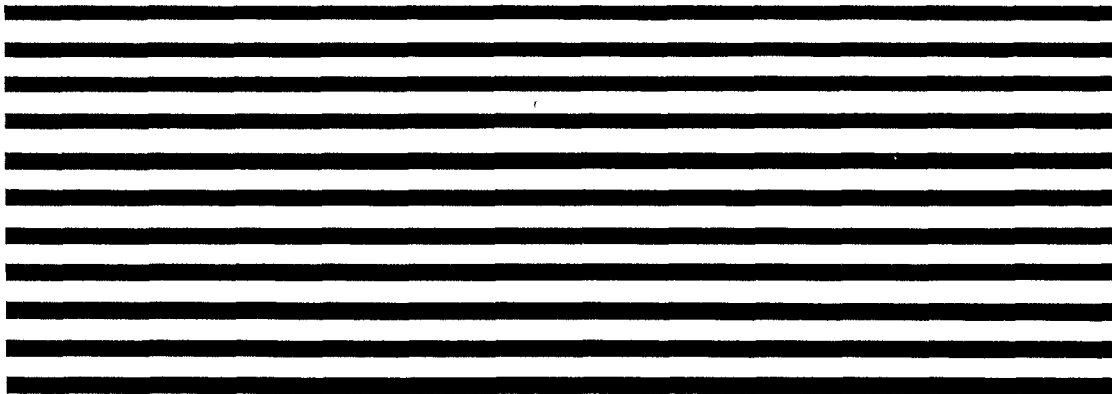

OPERATING MANUAL

Congratulations!

You're about to enter an exciting new world of vector synthesis combining Yamaha's advanced AWM sample playback technology with high-performance FM tone generation. Vector synthesis allows you to create and control synthesized sound with unprecedented ease — in a very intimate, "human" way, putting you more closely in touch with your instrument and music. The vector control lets you blend sounds manually in real time, and dynamic vectors let you "record" dynamic vector sweeps that will play automatically whenever you play a note. For even more expressive capability, the SY22 keyboard features both velocity sensitivity and after-touch response that can be assigned to a number of musical parameters. The more you play the SY22, the more you'll find that "vectors" will become an indispensable part of your musical repertoire.

- Yamaha AWM and FM tone generators for superior sound and tonal versatility.
- 2-element or 4-element voice architecture brings AWM and FM waveforms together.
- Vector control for 2-axis control of element level and detuning.
- Dynamic level and detune vectors can be recorded easily in real time.
- 128 preset AWM waveforms and 256 preset FM waveforms provide an extensive library of sonic "building blocks" from which to create new voices.
- 64 preset voices and 64 user voice memory locations.
- External memory cards provide limitless backup and storage capability.
- Easy-edit features make creating new voices quick and virtually programming-free.
- Detailed programming parameters for in-depth programming when necessary.
- Fully programmable 8-part multi-play mode is perfect for sequencer-driven applications and layered multi-voice performance.
- 16 internal digital effects including reverb, delay and distortion.
- Overlapping voice selection capability for seamless voice transitions.
- Velocity and after-touch sensitive keyboard.
- Pitch bend and modulation wheels.
- Stereo output.

CONTENTS

HOW TO USE THIS OPERATING MANUAL.....	1	PRECAUTIONS	2
		THE CONTROLS & CONNECTORS.....	3

TUTORIALS SECTION

1. SETTING UP YOUR SYSTEM.....	9	3. VECTORS.....	14
Connections.....	9	Voice Configurations.....	14
Power-on Procedure.....	9	Two Types of Vectors: Manual & Dynamic.....	14
Enjoy the Demos.....	10	Manual Vector Control.....	15
2. SELECTING AND PLAYING VOICES.....	11	An Exercise.....	16
The PRESET, INTERNAL and CARD Voice		Recording an Original Dynamic Vector.....	20
Memories.....	11	The STORE Key.....	23
Selecting the VOICE PLAY Mode, a Voice		Conclusion.....	24
Memory, and Voice	12	4. INSTANT VOICE PROGRAMMING.....	25
Overlapping Voice Selection.....	13	Conclusion.....	26

REFERENCE SECTION

VOICE COMMON.....	29	ELEMENT TONE.....	41
NAME.....	31	WAVE TYPE.....	43
CONFIGURATION	31	ELEMENT COPY.....	45
EFFECT (Type & Depth).....	31	FREQUENCY SHIFT.....	45
PITCH BEND.....	32	VOLUME.....	46
WHEEL (Amplitude & Pitch Modulation).....	32	PAN.....	46
AFTER TOUCH (Amplitude & Pitch Modulation,		VELOCITY SENSITIVITY.....	46
Pitch & Level Control).....	33	AFTER TOUCH SENSITIVITY.....	47
ENVELOPE (Attack & Release Rates).....	33	TONE (FM Elements B and D Only).....	47
RANDOM (Element, Level & Detune).....	34	LFO (Low Frequency Oscillator) AM Depth,	
VOICE VECTOR.....	35	PM Depth, Type, Delay, Rate & Speed	48
LEVEL SPEED (Vector Rate).....	37	ELEMENT ENVELOPE.....	51
LEVEL RECORD.....	37	TYPE.....	53
LEVEL EDIT (Step, X-axis, Y-axis & Time).....	37	ENVELOPE COPY.....	54
DETUNE SPEED (Vector Rate).....	39	DELAY (Delay Rate & Element ON/OFF).....	54
DETUNE RECORD.....	39	INITIAL LEVEL.....	54
DETUNE EDIT		ATTACK (Level & Rate).....	55
(Step, X-axis, Y-axis & Time).....	39	DECAY 1 (Level & Rate).....	55

DECAY 2 (Level & Rate).....	55	UTILITY RECALL.....	75
RELEASE RATE.....	56	UTILITY MIDI.....	79
LEVEL SCALING.....	56	MIDI ON/OFF.....	81
RATE SCALING.....	57	BASIC RECEIVE CHANNEL.....	81
MULTI.....	59	TRANSMIT CHANNEL.....	81
NAME.....	62	LOCAL CONTROL ON/OFF.....	82
EFFECT (Type & Depth).....	62	MIDI PROGRAM CHANGE.....	82
VOICE NUMBER.....	62	MIDI CONTROL CHANGE.....	82
MIDI RECEIVE CHANNEL.....	63	AFTER TOUCH ON/OFF.....	83
VOLUME.....	63	PITCH BEND ON/OFF.....	83
DETUNE.....	64	EXCLUSIVE ON/OFF.....	83
NOTE LIMIT (Low & High).....	64	ALL V/M TRANSMIT.....	84
NOTE SHIFT.....	64	1 VOICE TRANSMIT	84
UTILITY SETUP.....	67	APPENDIX.....	85
MASTER TUNE.....	69	SPECIFICATIONS.....	87
TRANSPOSE.....	69	ERROR MESSAGES.....	88
MEMORY CARD		INDEX.....	89
(Save, Load, Format, & Bank).....	69	MIDI DATA FORMAT.....	91
VOICE INITIALIZE.....	71	MIDI IMPLEMENTATION CHART.....	94
MULTI INITIALIZE.....	72		
MEMORY PROTECT (Internal & Card).....	73		

HOW TO USE THIS OPERATING MANUAL

This operation manual is broadly divided into two main sections — TUTORIALS and REFERENCE.

What's In the TUTORIALS Section

The TUTORIALS section contains four separate tutorials that take you step-by-step through the main procedures you will need to know to become familiar with your SY22:

1. SETTING UP YOUR SYSTEM [Page 9]
Basic system connections.
2. SELECTING AND PLAYING VOICES [Page 11]
Selecting and playing voices from the PRESET, INTERNAL and CARD voice banks.
3. VECTORS [Page 14]
Understanding and using manual and dynamic vectors.
4. INSTANT VOICE PROGRAMMING [Page 25]
The fast way to create an unlimited range of new voices for the SY22.

We recommend that you go through the tutorials in sequence while actually carrying out procedures on your SY22. Once you've gone through the entire TUTORIALS section in this way, you should be familiar enough with the SY22 to need only the REFERENCE section in future.

What's In the REFERENCE Section

The REFERENCE section is the "nuts and bolts" section of the manual, individually describing each of the SY22's many functions in detail. The REFERENCE section is divided into eight sub-sections, each describing the various functions within a particular SY22 edit or utility mode.

1. VOICE COMMON [Page 29]
2. VOICE VECTOR [Page 35]
3. ELEMENT TONE [Page 41]
4. ELEMENT ENVELOPE [Page 51]
5. MULTI [Page 59]
6. UTILITY SETUP [Page 67]
7. UTILITY RECALL [Page 75]
8. UTILITY MIDI [Page 79]

Once you have become familiar with the way the SY22 works by going through the TUTORIALS section, you should only need to refer to the REFERENCE section from time to time to get details on functions you've never used before, or refresh your memory about functions that you don't use very often.

Each sub-section of the REFERENCE section has its own table of contents, so you should be able to locate any particular function quickly and easily. Functions and references can also be located by referring to the INDEX at the back of the manual.

PRECAUTIONS

!! PLEASE READ THIS BEFORE PROCEEDING !!

- 1. Avoid Excessive Heat, Humidity, Dust and Vibration**

Keep the unit away from locations where it is likely to be exposed to high temperatures or humidity — such as near radiators, stoves, etc. Also avoid locations which are subject to excessive dust accumulation or vibration which could cause mechanical damage.
- 2. Avoid Physical Shocks**

Strong physical shocks to the unit can cause damage. Handle it with care.
- 3. Do Not Open The Case Or Attempt Repairs Or Modifications Yourself**

This product contains no user-serviceable parts. Refer all maintenance to qualified Yamaha service personnel. Opening the case and/or tampering with the internal circuitry will void the warranty.
- 4. Make Sure Power Is Off Before Making Or Removing Connections**

Always turn the power OFF prior to connecting or disconnecting cables.
- 5. Handle Cables Carefully**

Always plug and unplug cables by gripping the connector, not the cord.
- 6. Clean With a Soft Dry Cloth**

Never use solvents such as benzine or thinner to clean the unit. Wipe clean with a soft, dry cloth.
- 7. Always Use the Correct Power Supply**

Always use the supplied AC Adaptor to power your SY22 or, if the original adaptor is lost or broken, a replacement or equivalent type obtained from your Yamaha dealer. Also, make sure that the adaptor you have is appropriate for the AC mains supply voltage in the area where you intend to use the SY22 (the correct INPUT voltage is marked on the adaptor).
- 8. Electrical Interference**

Since the SY22 contains digital circuitry, it may cause interference and noise if placed too close to TV sets, radios or similar equipment. If such a problem does occur, move the SY22 further away from the affected equipment.
- 9. Memory Backup**

The SY22 contains a special backup power system that will retain the contents of the internal RAM memory for up to approximately one month even when the power is turned off! If the power is left off continuously for longer periods, the contents of the internal memory may be lost. Be sure to turn the SY22 on for a short period at least once a month if you wish to retain data in the internal memory.

THE CONTROLS & CONNECTORS

■ FRONT PANEL

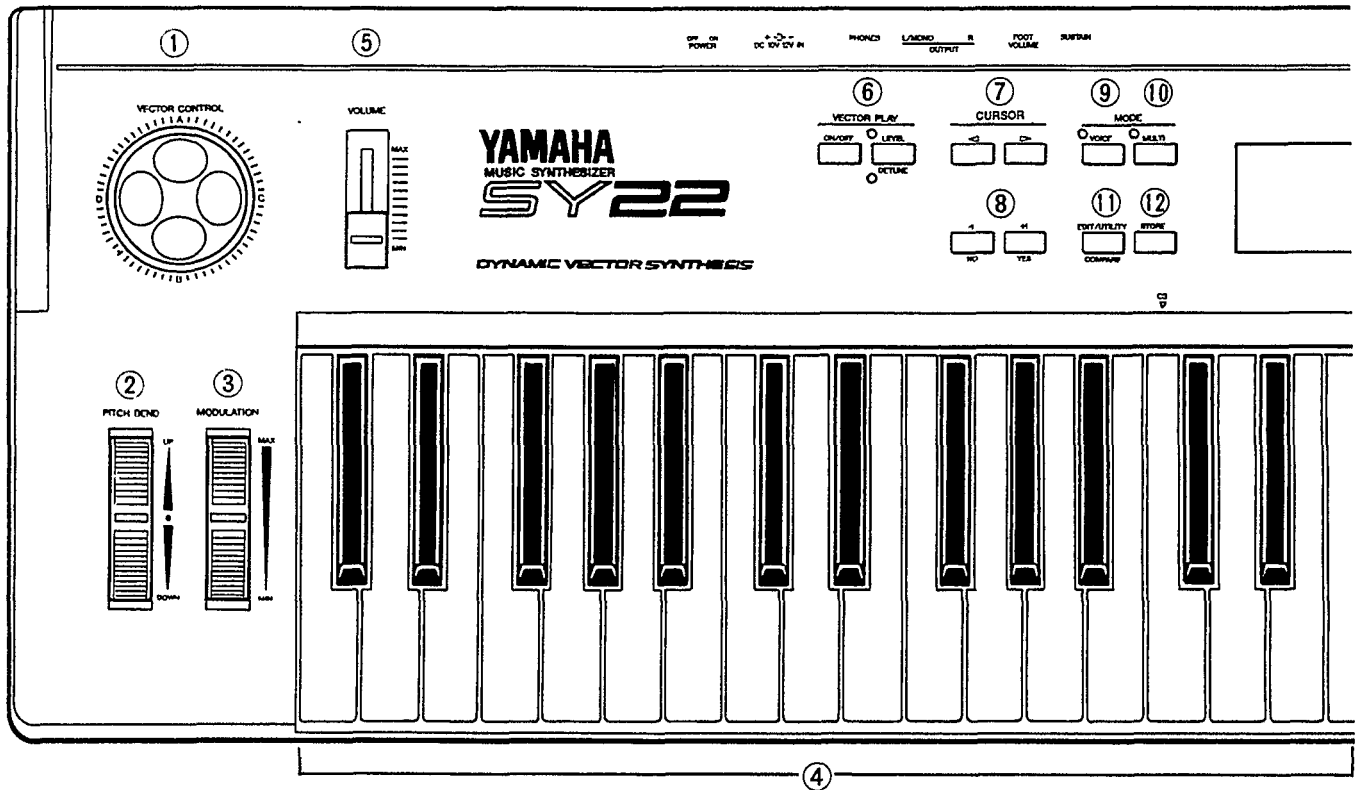

- 1 **[VECTOR CONTROL]**
This is the key to SY22's remarkable vector synthesis system. The [VECTOR CONTROL] allows manual control of level or detune for 2 or 4 voice "elements" simultaneously. It also allows realtime recording of dynamic level and detune vectors.
- 2 **[PITCH BEND] Wheel**
This self-centering pitch wheel allows smooth upward and downward pitch bends.
- 3 **[MODULATION] Wheel**
Can be assigned to apply pitch and/or amplitude modulation for a range of expressive effects.
- 4 **Keyboard**
The SY22 keyboard is both velocity and after-touch sensitive for broad, intimate expressive control.
- 5 **VOLUME Control**
Adjusts the volume of the sound delivered via the rear-panel OUTPUT and PHONES jack.
- 6 **VECTOR PLAY [ON/OFF] and [LEVEL/DETUNE] Keys & Indicators**
The [ON/OFF] key turns manual vector control on or off, while the [LEVEL/DETUNE] key selects level or detune control.
- 7 **[<] and [>] Cursor Keys**
Move the screen cursor from parameter to parameter in many of the SY22 editing functions.

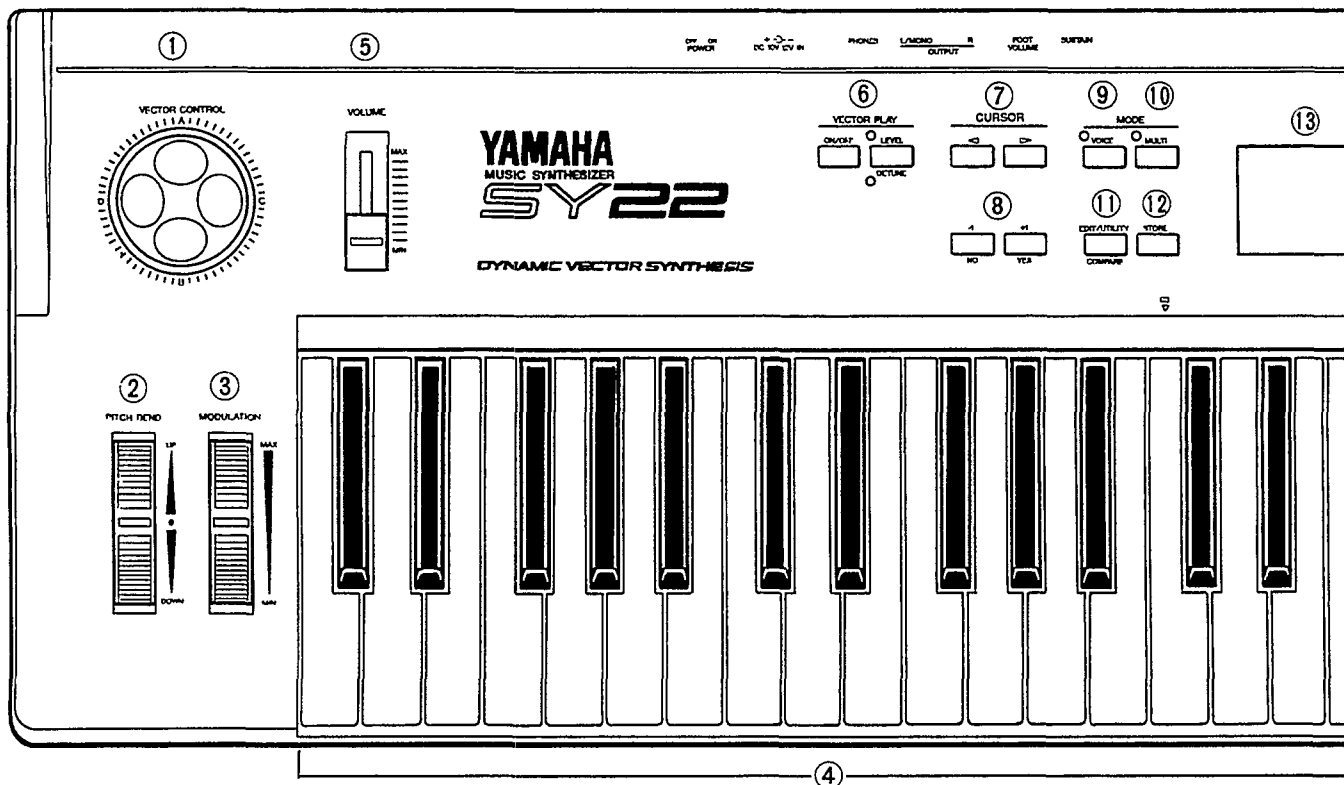

⑧ [-1/NO] and [+1/YES] Keys

Can be used to select voices and multi-play setups, and are used to edit parameter values in any of the SY22 edit modes. Either key can be pressed briefly for single stepping in the specified direction, or held for continuous scrolling. These keys are also used to answer the "Are you sure?" confirmation prompt when saving or initializing data.

⑨ [VOICE] Key & Indicator

Selects the normal voice play mode in which any of the SY22's preset, internal or card voices can be played via the keyboard or other controller connected to the MIDI IN connector.

⑩ [MULTI] Key & Indicator

Selects the multi-play mode in which up to 8 voices can be played simultaneously via the keyboard or controlled on different MIDI channels via an external MIDI sequencer.

⑪ [EDIT/UTILITY/COMPARE] Key

Accesses the SY22's voice edit, multi-play edit and utility modes. Also activates the compare function when in any edit mode, allowing quick comparison of the original and edited voice or multi-play setup.

⑫ [STORE] Key

Used to store the selected voice on multi-play setup to an internal or card memory location.

⑬ LED Display

This 2-digit 7-segment LED numeric display shows the bank and number of the currently selected voice or multi-play setup in the VOICE PLAY or MULTI PLAY mode. It also indicates when an edit or utility mode is active, and shows the character — A, B, C or D — of the currently selected element in one of the element edit modes.

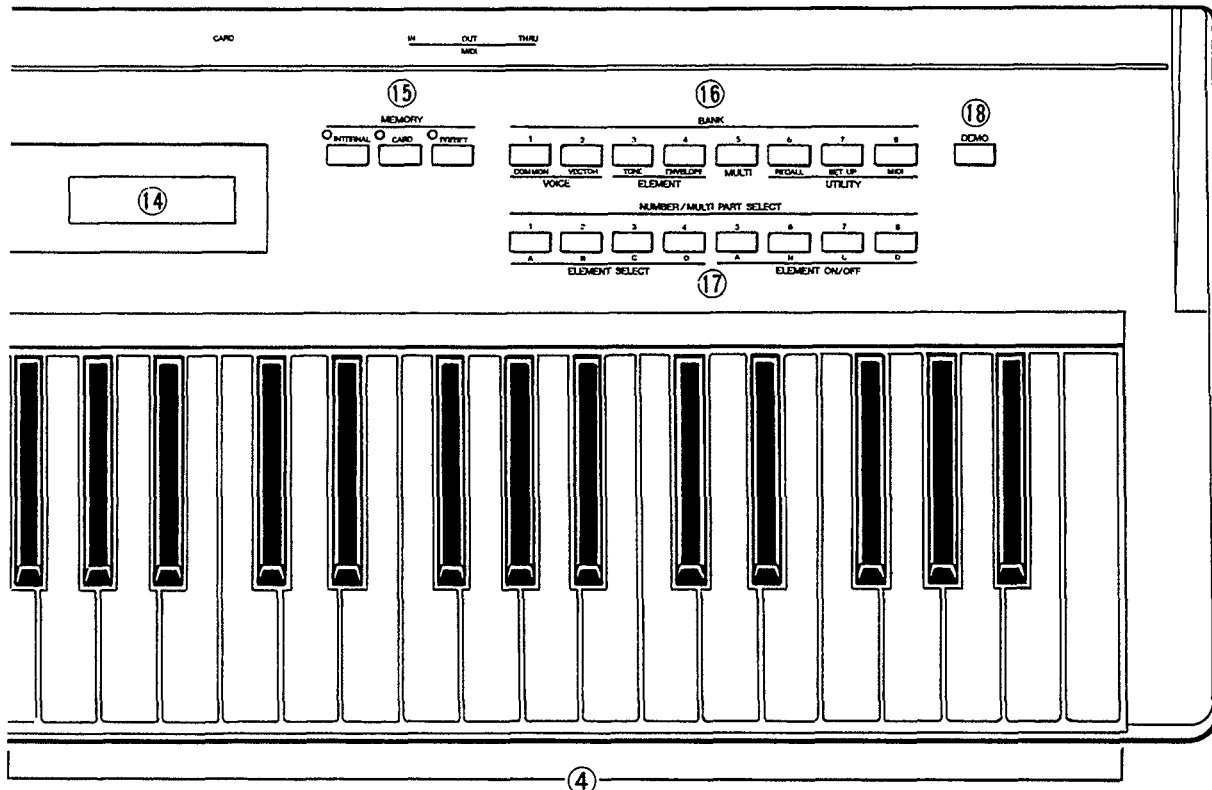

14) Liquid Crystal Display Panel

This 16-character x 2-line backlit liquid crystal display panel shows the selected voice or multi-play setup name in the voice or multi-play modes, as well as function names and parameters in the utility and edit modes.

15) [INTERNAL], [CARD], and [PRESET] Keys & Indicators

Select the data bank — preset, internal or card — from which voices or multi-play setups will be selected.

[BANK] Select and Edit/Utility Mode Access keys

In the VOICE PLAY or MULTI PLAY mode, these keys — [1] through [8] — are used to select the bank of the voice or multi-play setup to be selected.

In an edit or utility mode, or immediately after the [EDIT/UTILITY] key has been pressed to access these modes, these keys are used to selected the desired edit or utility function group (green labels below the keys).

17) [NUMBER/MULTI PART SELECT] and Element Control Keys

In the VOICE PLAY or MULTI PLAY mode, these keys — [1] through [8] — are used to select the number of the voice or multi-play setup to be selected.

In the MULTI edit mode they select the multi-play part to be edited, and in the ELEMENT TONE or ELEMENT ENVELOPE edit mode they are used to select individual elements and turn individual elements on and off for editing (green labels below the keys).

18) [DEMO] Key

Activates the SY22 built-in demonstration — a great way to hear what the SY22 can do after you set up your system.

■ REAR PANEL

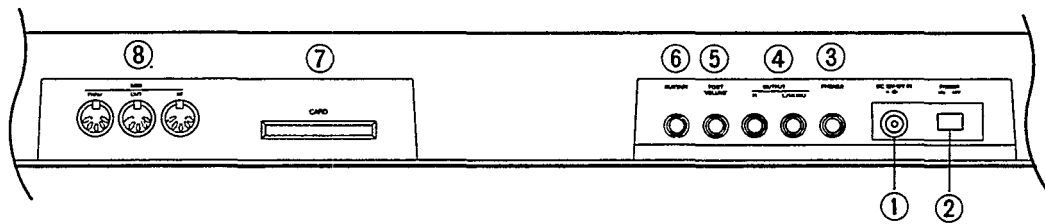

① DC 10V-12V IN Jack

The DC output cable from the supplied AC Adaptor should be connected here. When connecting the power supply, make sure that the SY22 POWER switch is in the OFF position (extended), then plug the AC adaptor output cable into the DC 10V-12V IN jack, and finally the adaptor's AC plug into a convenient AC wall outlet. The cable clip located immediately below the DC 10V-12V IN jack helps to prevent accidental unplugging of the power supply during use. Wrap the DC cable firmly around the clip a few centimeters from the plug end.

CAUTION!

Do not attempt to use a different AC adaptor to power the SY22. The use of an incompatible adaptor may cause irreparable damage to the SY22, and might pose a serious shock hazard!

② [POWER] Switch

Slide to the "ON" position to turn power ON.

③ PHONES Jack

Accepts a standard pair of stereo headphones (1/4" stereo phone plug) for headphone monitoring of the SY22 sound without the need for external amplification equipment.

④ OUTPUT R and L/MONO Jacks

These are the main stereo outputs from the SY22. If a plug is inserted only into the L/MONO jack, the left and right-channel signals are combined and delivered via this jack (for connection to a monaural sound system).

⑤ FOOT VOLUME Jack

An optional Yamaha FC-7 foot controller connected here can be used for volume control.

⑥ SUSTAIN Jack

An optional Yamaha FC-4 or FC-5 footswitch can be connected here for press-on/release-off sustain control.

⑦ CARD Slot

The CARD slot accepts Yamaha MCD64 or MCD32 Memory Cards for storage and retrieval of SY22 voices.

⑧ MIDI IN, OUT and THRU Connectors

The MIDI IN connector receives the data from a sequencer or other MIDI controller which is to control the SY22. The MIDI THRU connector simply re-transmits the data received at the MIDI IN connector, allowing convenient chaining of MIDI devices. The MIDI OUT connector transmits data corresponding to all SY22 performance operations, or bulk data when one of the MIDI voice data transmission functions are activated.

TUTORIALS SECTION

1. SETTING UP YOUR SYSTEM

Connections

The diagram below shows the basic connections in a setup using only the SY22 and a stereo sound system.

CAUTION!!: Make sure that both the SY22 and your sound system are turned OFF when making connections.

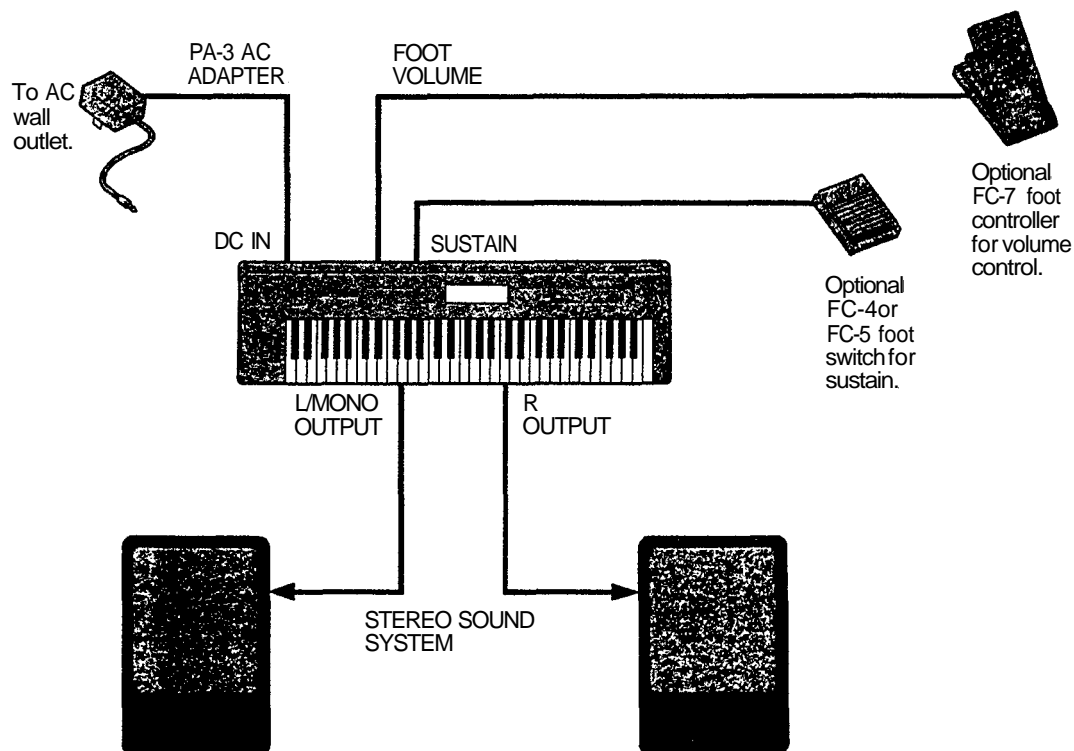

Power-on Procedure

1. Make sure your sound system's volume control and the SY22 volume control are turned all the way down prior to turning power on.
2. Turn on the SY22.
3. Turn on the sound system.
4. Raise the sound system volume to a reasonable level.
5. Gradually raise the SY22 VOLUME control while playing the keyboard to set the desired listening level.

Caution: The SY22 automatically transmits MIDI control change data corresponding to its control status when its power switch is turned ON or OFF. This can interfere with operation of other MIDI equipment connected to the SY22 MIDI OUT connector. If the SY22 is connected to other MIDI equipment, the SY22 power switch should be ON *first*, and turned OFF *last*.

Enjoy the Demo

The SY22 is programmed with a demonstration sequence that you might enjoy listening to after setting up your system. Take a short break and enjoy the demo:

1. Press the [DEMO] key. "Yes to Start" will appear on the LCD display.
2. Press the [+1/YES] key to start demo playback. "No to Stop" will appear on the LCD display.
3. Press the [-1/NO] key when you want to stop demo playback.

2. SELECTING AND PLAYING VOICES

The PRESET, INTERNAL and CARD Voice Memories

Here's a global view of the SY22 system:

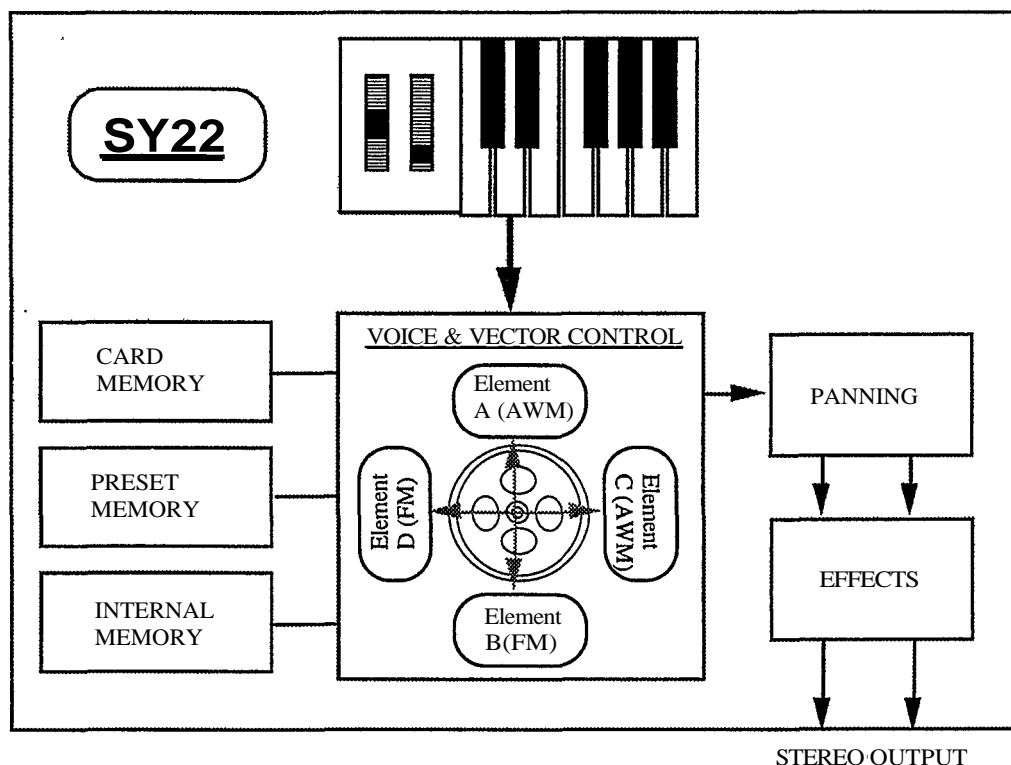

Please note that the voices played by the SY22 can come from three different sources: the PRESET voice memory, the INTERNAL voice memory, or a CARD voice memory:

PRESET

The PRESET voice memory contains 64 pre-programmed voices in ROM (Read Only Memory) that cannot be overwritten or changed in any way. The PRESET voice memory is represented on the display by the letter "P".

PRESET VOICE LIST

	No.	Voice Name	EL*		No.	Voice Name	EL*		No.	Voice Name	EL*		No.	Voice Name	EL*
1	1.1	Genesis	4	17	3.1	Piano	2	33	5.1	Oboe	2	49	7.1	Inca	4
2	1.2	DXlegend	4	18	3.2	PinPiano	4	34	5.2	Sax	2	50	7.2	Voyager	4
3	1.3	Full Str	4	19	3.3	Elekroad	2	35	5.3	12String	4	51	7.3	Crystals	4
4	1.4	Dist Gtr	4	20	3.4	MalletEP	4	36	5.4	Mute Gtr	4	52	7.4	VCO Sync	4
5	1.5	Itopia	4	21	3.5	Clavi	2	37	5.5	WoodBass	2	53	7.5	VCO Lead	4
6	1.6	PowerBrs	4	22	3.6	ThinClav	2	38	5.6	PlukBass	2	54	7.6	MiniLead	2
7	1.7	RainNite	4	23	3.7	RokOrgan	2	39	5.7	FunkBass	2	55	7.7	Groover	2
8	1.8	Nostramo	4	24	3.8	JazOrgan	4	40	5.8	SlapBass	4	56	7.8	Digicord	2
9	2.1	Matrix22	4	25	4.1	PipeOrgn	2	41	6.1	Fretless	2	57	8.1	SuperPad	4
10	2.2	Arpegi8	4	26	4.2	Trumpet	2	42	6.2	Syn Bass	2	58	8.2	Prophecy	4
11	2.3	SadAngel	4	27	4.3	Trombone	4	43	6.3	Strings	4	59	8.3	Industry	4
12	2.4	DynaPad	4	28	4.4	Fr Horn	2	44	6.4	Chamber	2	60	8.4	Evolver	4
13	2.5	IceField	4	29	4.5	BrasSect	4	45	6.5	Syn Str	4	61	8.5	VectaEko	4
14	2.6	Nautilus	4	30	4.6	Fanfare	4	46	6.6	BoyChoir	4	62	8.6	Zombie	4
15	2.7	VectaSeq	4	31	4.7	FatBrass	4	47	6.7	Marimba	2	63	8.7	Rap Perc	4
16	2.8	Thriller	4	32	4.8	Flute	2	48	6.8	BellWah	4	64	8.8	Dr.Kit	2

*EL = No. of elements.

INTERNAL

The INTERNAL voice memory is a RAM (Random Access Memory) area into which you can store up to 64 voices that you create or load from an external memory card. The INTERNAL voice memory is represented on the display by the letter "I".

CARD

The CARD memory bank is a Yamaha MCD64 or MCD32 Memory Card (or pre-programmed voice card) plugged into the SY22 CARD slot on the rear panel. Memory cards are convenient for external storage and transportation of voices that you or others create. You can also store sets of related voices on different memory cards. An MCD32 Memory Card allows storage of up to 64 voices. An MCD64 Memory Card holds two banks of 64 voices each — a total of 128 voices per card (REFERENCE SECTION, page 70). The CARD voice memory is represented on the display by the letter "C".

Note: No warning is given on the SY22 displays when a memory card backup battery is about to fail. See your memory card owner's manual for details.

Any voice in any of these voice memories can be selected and played while the SY22 is in the VOICE PLAY mode.

Selecting the VOICE PLAY Mode, a Voice Memory, and Voice

1. If the VOICE PLAY mode is not already selected — as indicated by a lit [VOICE] key LED and "VOICE PLAY" across the top of the LCD — press the [VOICE] key to select it.



The image shows a rectangular LCD display with a black border. The text is displayed in a pixelated, monospaced font. The top line reads "VOICE PLAY" and the bottom line reads "P11 Genesis".

2. The [INTERNAL], [CARD], and [PRESET] keys are used to select the desired voice memory. If no memory card is inserted in the CARD slot, the "Card not ready!" display will appear if you attempt to select the card voice memory.
3. The 64 voices in each voice memory are organized into 8 banks of 8 voices each ($8 \times 8 = 64$). Any voice can be selected by specifying its bank using the BANK keys, and its number using the NUMBER/MULTI PART SELECT keys.
Voice numbers are displayed on the LCD in the same way. "2,5" for example, is not preset voice number 25, but rather preset voice bank 2, number 5. On the large LED display, this would be shown as "2.5". The 64th preset voice, therefore, is displayed as "P88" on the LCD or "8.8" on the LED display. To select voice bank 4 number 7, for example, press the BANK [4] key and NUMBER/MULTI PART SELECT [7] key — in any order.

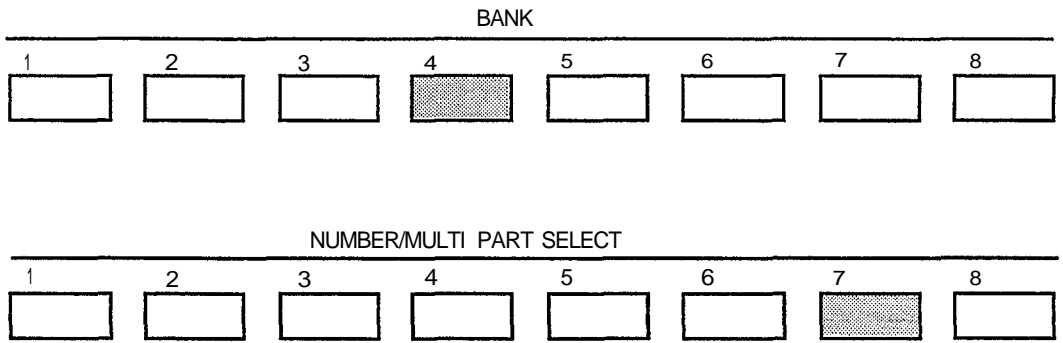

The displays should look something like this:

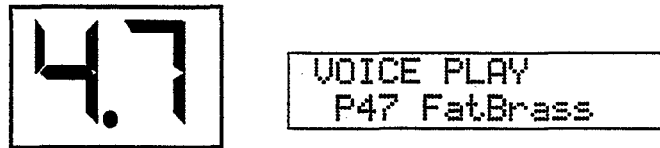

To select a different number within the same bank it is only necessary to press the appropriate NUMBER key. In the same way, to select the same number in a different bank all you have to do is press the appropriate BANK key.

The [-1/NO] and [+1/YES] keys can also be used to select a voice in the VOICE PLAY mode. Holding the [-1/NO] or [+1/YES] key causes continuous scrolling in the specified direction.

4. Play the keyboard.

If you don't get any sound at this point:

- Make sure your sound system is turned ON and the volume is turned up to a reasonable level.
- Make sure that the SY22 VOLUME control is turned up to a reasonable level.
- Check all connections carefully.

Overlapping Voice Selection

The SY22 has been designed to allow overlapping voice selection. That is, if you select a new voice while holding notes on the keyboard (or by using a sustain footswitch), the held notes will continue playing the previous voice while subsequently played notes will use the new voice. Although the primary reason for this feature is to allow smooth switching between voices without unnatural sound cutoff or gaps, it is actually possible to play several voices at once by holding a note or two, selecting a new voice, holding a couple more notes, selecting a second new voice, and so on. Please note, however, that if different voices selected using this method have different effects, a corresponding change in effect will be heard.

3. VECTORS

Voice Configurations

SY22 voices can have either a 2-element or 4-element configuration (REFERENCE SECTION, page 31). Each "element" is actually an independent sound or "waveform," and vector control allows the 2 or 4 different waveforms in a voice to be blended and detuned in a variety of ways — manually or automatically.

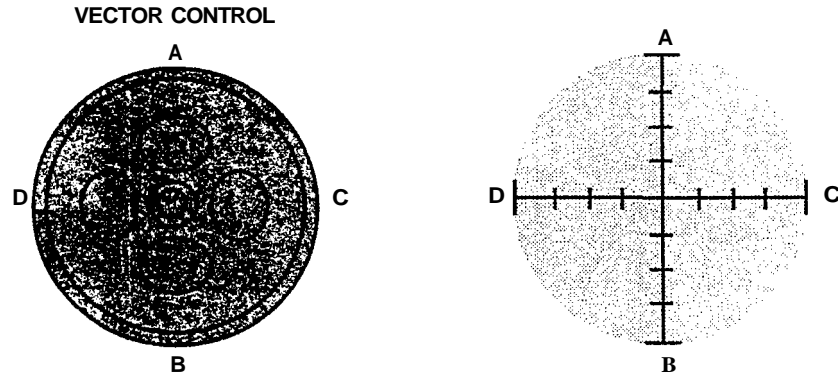

For the sake of clarity, we'll represent the SY22 vector control by a simple graph like the one shown to the right for the rest of the tutorial.

The "A," "B," "C," and "D" markings around the [VECTOR CONTROL] correspond to the voice elements. A 2-element voice uses only elements A and B, while a 4-element voice uses all four elements — A, B, C and D.

Elements A and C are *always* AWM elements, while B and D are *always* FM elements. When you start programming your own voices you can assign any of 128 preset AWM waveforms to elements A and C, and any of 256 preset FM waveforms to elements B and D (REFERENCE SECTION, page 43).

AWM & FM: AWM stands for "Advanced Wave Memory," Yamaha's sophisticated sampling technology that allows high-fidelity reproduction of digitally recorded "live" sound. FM is Yamaha's proven Frequency Modulation synthesis technology which is capable of creating extraordinarily warm, vibrant simulations of actual instruments, as well as an infinite variety of original sounds.

Two Types of Vectors: Manual & Dynamic

Vector control can be accomplished in two ways: manually by operating the [VECTOR CONTROL] while playing, or automatically. Automatic vectors are called "dynamic vectors" in the SY22, and these play automatically whenever you play a note on the keyboard. Dynamic vectors can be recorded in real time via the [VECTOR CONTROL] by using the procedure described in the "Recording an Original Dynamic Vector" section on page 20. Dynamic vectors function whenever the VECTOR PLAY mode is OFF — i.e. when both the VECTOR PLAY [LEVEL] and [DETUNE] indicators are out.

Manual vector control is possible whenever the VECTOR PLAY mode is ON — i.e. when either the VECTOR PLAY [LEVEL] or [DETUNE] indicator is lit.

Manual Vector Control

Manual vector control while playing can be accomplished by turning the vector play mode on — press the VECTOR PLAY [ON/OFF] key so that either the [LEVEL] or [DETUNE] indicator lights, and then select either level or detune control by pressing the VECTOR PLAY [LEVEL/DETUNE] key.

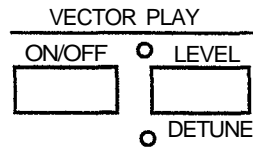

The [VECTOR CONTROL] can then be used to control the selected parameter — level or detune — along the vertical axis only if a 2-element voice is selected, or along both the vertical and horizontal axes if a 4-element voice is selected.

2-ELEMENT VOICE

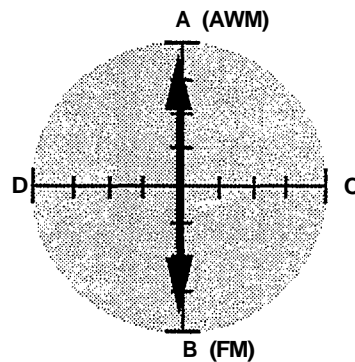

4-ELEMENT VOICE

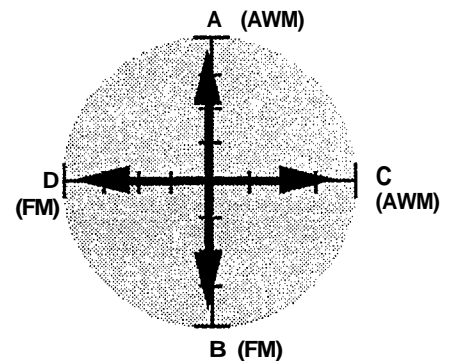

When level vector control is selected, moving the control towards one element (A, B, C or D) increases the level of that element while decreasing the level of the others proportionally. The [VECTOR CONTROL] works in a similar way when detune vector control is selected — moving the control towards one element increases the pitch of that element while decreasing the pitch of the others.

If the selected voice has a dynamic detune vector, the detune vector will play while manual level vector control is selected, and vice versa.

The following diagrams should give you a rough idea of how the level or pitch of each element in a 4-element voice is affected by [VECTOR CONTROL] motion.

VECTOR CONTROL MOTION

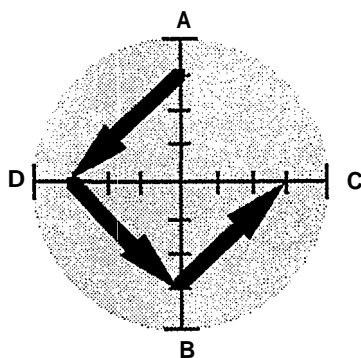

LEVEL OR PITCH CHANGE

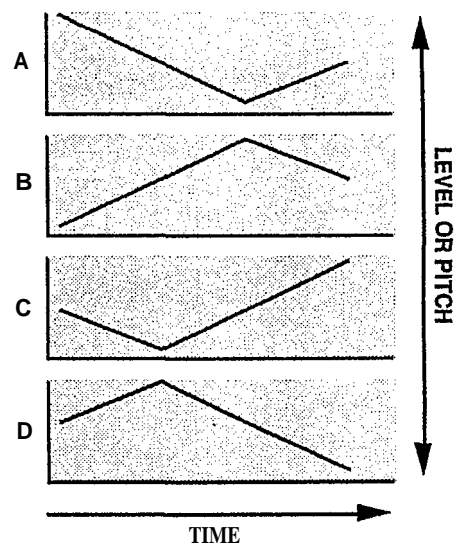

An Exercise

The best way to discover what vector control can do for you is to listen and experiment. Here's a list of the preset voices including the configuration of each (2 or 4-element) and the names of the waveforms assigned to each element.

PRESET VOICE Performance Note

No.	Voice Name	EL	Vector	Waveforms	Effects	Notes
1.1	Genesis	4	Yes/No	043 Choir 103Sus.6 126SEQ8 111 Sus.14	RevHall	Play long notes. Switch on VECTOR PLAY LEVEL, turn VECTOR CONTROL to C, hear SEQ 8 wave (Sequence wave)
1.2	DXlegend	4	No/Yes	001 E.Piano 072Vibes3 001 E.Piano 072Vibes3	Rev Hall	Electronic piano
1.3	Full Str	4	No/Yes	039 Vn.Ens. 068 Str 6 038 Strings 069 Str 7	RevHall	Light touch for small, heavy for large string section. After-touch volume.
1.4	Dist Gtr	4	Yes/No	022 E.Gtr 1 157 Square 098 Digital2 193Wave8-1	Dist&Rev	Heavy guitar. Slow fade to feedback. Switch on VECTOR PLAY LEVEL, turn VECTOR CONTROL from A to D, B, C for manual feedback.
1.5	Itopia	4	Yes/Yes	044 Itopia 103Sus.6 044 Itopia 233Wave21-2	Rev Hall	Breathy choir After-touch volume.
1.6	PowerBrs	4	No/Yes	102 Saw 1 095 Lead 5 102 Saw 1 095 Lead 5	Rev Hall	Powerful analog brass pad. After-touch vibrato.
1.7	RainNite	4	Yes/Yes	085 Str. Body 235Wave22-1 068 Coin 220Wave17-1	Rev Metal	Best with long chords.
1.8	Nostromo	4	Yes/No	055 Hit 061 Bass 8 049 Timpani 122 Move 5	Rev Hall	Best with long chords. After-touch vibrato.

*EL = No. of elements

*2 = Vector

Yes/Yes

↑ ↑

LEVEL VECTOR DETUNE VECTOR

No.	Voice Name	EL	Vector	Waves	Effect	Comments	
9	2.1	Matrix22	4	Yes/Yes	039 Vn.Ens. 121 Move 4 038 Strings 122 Move 5	Rev Hall	Big orchestra with sweeping brass.
10	2.2	Arpeggi8	4	Yes/Yes	044 Itopia 061 Bass 8 038 Strings 043 Clavi 2	Rev Metal	Play broken chords (arpeggios) and hold down each note of the arpeggio. The late envelope will echo what you play.
11	2.3	SadAngel	4	No/Yes	044 Itopia 122 Move 5 044 Itopia 122 Move 5	Pan Ref	Best with long notes. Pitch bending by LFO.
12	2.4	DynaPad	4	Yes/Yes	044 Itopia 111 Sys. 14 080 Slam 077 Bells 1	PanRef	Best with long notes.
13	2.5	IceField	4	Yes/Yes	043 Choir 121 Move 4 043 Choir 122 Move 5	Rev Metal	Best with long chords.
14	2.6	Nautilus	4	Yes/Yes	067 Stream 115 Attack 3 038 Strings 016 Brass 3	Pan Ref	Best with long chords.
15	2.7	VectaSeq	4	Yes/No	042 SynStr. 023 Brass 10 093 Gtr wv 067 Str 5	Rev Hall	4 note sequence voice by Vector. Switch on VECTOR PLAY LEVEL, turn VECTOR CONTROL for manual sequence.
16	2.8	Thriller	4	Yes/Yes	055 Hit 123 Move 6 068 Coin 166 Digi 6	PanRef	Best with long notes.
17	3.1	Piano	2	No/No	000 Piano 005 E.Piano6	Rev Club	Orthodox acoustic piano
18	3.2	PinPiano	4	No/Yes	090 EP wv 188 Wave 6-2 000 Piano 005 E.Piano6	Rev Hall	Electric piano with brilliant attack like "Prepared piano"
19	3.3	Elekroad	2	No/No	004 Celesta 002 E.Piano3	Rev Room	Dark Electronic piano.
20	3.4	MalletEP	4	No/Yes	001 E.Piano 071 Vibes 2 001 E.Piano 071 Vibes 2	Rev Hall	Electric piano with sharp attack.
21	3.5	Clavi	2	Yes/Yes	002 Clavi 042 Clavi 1	Early Ref	Fat, funky clavi.
22	3.6	ThinClav	2	No/No	058 Sync 043 Clavi 2	Early Ref	Funky clavi with wide touch range.
23	3.7	RokOrgan	2	Yes/No	006 E.Organ1 007 E.Organ2	Pan Ref	Rock Organ. After-touch vibrato.
24	3.8	JazOrgan	4	No/Yes	007 E.Organ2 007 E.Organ2 007 E.Organ2 007 E.Organ2	Delay 1	Full, rich organ with rotating speaker effect. Add more effect by using VECTOR PLAY.
25	4.1	PipeOrgn	2	No/Yes	005 P.Organ 008 E.Organ3 008 E.Organ3	Rev Hall	Big Church Organ
26	4.2	Trumpet	2	No/No	009 Trumpet 017 Brass 4	Rev Hall	Solo trumpet. After-touch vibrato.
27	4.3	Trombone	4	Yes/Yes	011 Trombone 017 Brass 4 011 Trombone 024 Brass 11	Rev Room	Solo trombone After-touch vibrato.

*EL = No. of elements.

*2 = Vector

Yes/Yes
 ↑ ↑
 LEVEL VECTOR DETUNE VECTOR

	No.	Voice Name	EL*	Vector**	Wave	Effect	Comments
28	4.4	FrHorn	2	No/No	013FrHorn 236 Wave22-2	Rev Hall	French Horn ensemble After-touch vibrato.
29	4.5	BrasSect	4	No/No	009 Trumpet 016 Brass 3 011 Trombone 017 Brass 4	Early Ref	Pop brass section. Switch on VECTOR PLAY LEVEL, turn VECTOR CONTROL for various brass color.
30	4.6	Fanfare	4	No/Yes	082 Tb.Body 016 Brass 3 011 Trombone 017 Brass 4	Rev Hall	Classical brass section. After-touch vibrato.
31	4.7	FatBrass	4	No/Yes	015SynBrass 026 Brass 13 015SynBrass 026 Brass 13	Early Ref	Fat synthClub brass pad.
32	4.8	Flute	2	No/No	016 Flute 062 Bass 9*	Rev Room	Solo flute
33	5.1	Oboe	2	No/Yes	018 Oboe 036 Reed 1	Rev Hall	Solo oboe After-touch vibrato.
34	5.2	Sax	2	Yes/No	019 Sax 041 Reed 6*	Early Ref	Solo sax After-touch vibrato.
35	5.3	12String	4	Yes/Yes	021 Steel 044 Clavi 3 021 Steel 196Wave9-1	Pan Ref	Full 12 strings guitar
36	5.4	Mute Gtr	4	No/Yes	023E.Gtr2 052 Gtr 7 024 Mute Gtr 050 Gtr 5	Rev Hall	Light touch for muted, heavy for normal electric guitar. After-touch vibrato.
37	5.5	WoodBass	2	No/No	028 Wood B1 055 Bass 2	Rev Room	Woodbass After-touch vibrato.
38	5.6	PlukBass	2	Yes/Yes	032 E.Bass 3 056 Bass 3	Rev Club	Picked bass
39	5.7	FunkBass	2	Yes/Yes	031 E.Bass 2 057 Bass 4	Delay 1	Punchy picked bass
40	5.8	SlapBass	4	Yes/Yes	031 E.Bass 2 057 Bass 4 034 Slap 056 Bass 3	Gate Rev	Play hard for slap bass sound.
41	6.1	Fretless	2	No/No	035 Fretless 055 Bass 2	Rev Room	Fretless bass After-touch vibrato.
42	6.2	Syn Bass	2	No/No	037 SynBass2 138 Decay 14	Delay 1	Funky synth bass.
43	6.3	Strings	4	No/Yes	038 Strings 064 Str 2 038 Strings 064Str2	Rev Hall	Large string section
44	6.4	Chamber	2	Yes/Yes	039 Vn.Ens. 063 Str 1	Rev Room	Small violin section
45	6.5	Syn Str	4	No/Yes	042 Syn Str 063Str1 042 Syn Str 063Str1	Rev Hall	Analog synth strings. Switch on VECTOR PLAY LEVEL, turn VECTOR CONTROL for various strings voice color.
46	6.6	BoyChoir	4	No/Yes	043 Choir 073 Vibes 4* 043 Choir 000E.Piano1*	Rev Hall	Choir
47	6.7	Marimba	2	No/No	047 Marimba 059 Bass 6	Early Ref	Traditional marimba

*EL = No. of elements

** = Vector

Yes/Yes

↑ ↑

LEVEL VECTOR DETUNE VECTOR

	No.	Voice Name	EL*	Vector**	Wave	Effect	Comments
46	6.8	Bell Wah	4	Yes/No	044 Itopia 143 SFX 1 043 Choir 071 Vibes 2	Rev Hall	Percussive bell with cornig up choir. Best with long notes. After-touch choir volume
49	7.1	Inca	4	Yes/Yes	070 Bottle 093 Lead 3 015SynBrass 239Wave23-2	PanRef	
50	7.2	Voyager	4	No/No	044 Itopia 106Sus.9 059 Bell Mix 056 Bass 3	Rev Plate	Choir with "sizzle." Play long chords.
51	7.3	Crystals	4	No/No	068 Coin 073 Vibes 4 056 Harmonic 102Sus.5	Rev Plate	
52	7.4	VCO Sync	4	Yes/Yes	036 SynBass1 058 Bass 5 106 Square 1 093 Lead 3	Pan Ref	Fat analog synth lead voice. After-touch vibrato.
53	7.5	VCO Lead	4	Yes/Yes	042 Syn Str 092 Lead 2 100 Digital4 097 Lead 7	Delay 2	Powerful synth lead voice. After-touch vibrato.
54	7.6	MiniLead	2	Yes/Yes	108 Square 3 157 Square	Rev Club	Analog square lead voice. After-touch vibrato.
55	7.7	Groover	2	No/Yes	036 SynBass1 062 Bass 9	Gate Rev	Funky synth pad.
56	7.8	Digicord	2	Yes/Yes	101. Digital5 045 Clavi 4	Rev Plate	Useful synth harpsichord voice for pad.
57	8.1	SuperPad	4	Yes/Yes	102 Saw 1 061 Bass 8 015 SynBrass 061 Bass 8	Pan Ref	Powerful fat synth pad. Use VECTOR CONTROL for various color of voice.
58	8.2	Prophecy	4	Yes/Yes	083 HornBody 121 Move 4 096 Pad wv 121 Move 4	Rev Hall	Warm sweeping synth voice. Best with long chords.
59	8.3	Industry	4	Yes/Yes	125SEQ7 104Sus.7 038 Strings 122 Move 5	Rev Hall	Strings with sequence wave. Best with long chords.
60	8.4	Evolver	4	Yes/No	056 Harmonic 054 Bass 1 038 Strings 118 Move 1	Rev Hall	Dynamic moving voice. Best with long notes.
61	8.5	VectaEko	4	Yes/Yes	113Pulse4 193 Wave8-1 111 Pulse 2 190 Wave7-1	Rev Hall	Best with long notes.
62	8.6	Zombie	4	Yes/Yes	122SEQ4 144 SFX 2 123SEQ5 145 SFX 3	Rev Hall	Sound effects voice. Best with long notes.
63	8.7	Rap Perc	4	No/Yes	087 Reverse1 143 SFX 1 088 Reverse2 143 SFX 1	Early Ref	Rap Percussion.
64	8.8	Dr.Kit	2	No/No	127 Drum set 000E.Piano1*	Rev Plate	Drum set including sound effects.

*EL = No. of elements

**2 = Vector

Yes/Yes
 ↑ ↑
 LEVEL VECTOR DETUNE VECTOR

Voice number P88 provides a complete drum kit plus a range of valuable percussion sounds. The voice is set up so that each key on the keyboard produces a different drum sound, as shown in the list below. The Dr.Kit voice can be used on its own, or as a source of drums and percussion in a multi-play setup (REFERENCE section, page 59).

Voice Number P88 Dr.Kit: Drum-set Voice

Key	Wave Name	Key	Wave Name	Key	Wave Name
C1	BD1	C3	Crash 2	C5	SD4
C#1	Triangle closed	C#3	Splash	C#5	Low Scratch
D1	SD1	D3	Cup	D5	SD5
D#1	Triangle open	D#3	Ride	D#5	High Scratch
E1	E.Tom 1	E3	Low Conga	E5	Reverse Cymbal
F1	E.Tom 2	F3	High Conga	F5	Slam1
F#1	E.Tom 3	F#3	Mute Conga	F#5	Coin
G1	E.Tom 4	G3	DigiAttack	G5	Slam 2
G#1	BD2	G#3	Ooo!	G#5	Water Drop
A1	BD3	A3	Low Timbales	A5	Low Timpani
A#1	Cross Sticks	A#3	High Timbales	A#5	Cracker
B1	Tom 1	B3	Tambourine	B5	High Timpani
C2	Tom 2	C4	Finger snaps	C6	Metal Hit
C#2	SD2	C#4	Claves		
D2	Tom 3	D4	Low Agogo		
D#2	Rim	D#4	High Agogo		
E2	SD3	E4	Low Cuica		
F2	Tom 4	F4	High Cuica		
F#2	Claps	F#4	Low Whistle		
G2	Cowbell 1	G4	High Whistle		
G#2	Shaker	G#4	Bambo		
A2	HH closed	A4	Bottle		
A#2	Crash 1	A#4	Cowbell 2		
B2	HH open	B4	Crash		

Select the "Evolver" voice, turn the VECTOR PLAY mode ON, select level control, and use the [VECTOR CONTROL] to listen carefully to the sound of the various elements and how they interact when the [VECTOR CONTROL] is moved. Repeat this process with a number of different voices and you'll quickly begin to hear how powerful and versatile vector synthesis can be.

Recording an Original Dynamic Vector

Before you begin recording your own dynamic vector, select the "Evolver" voice (P84), make sure the manual VECTOR PLAY mode is turned OFF (neither the [LEVEL] or [DETUNE] indicators should be lit), and play a nice long note or chord. Notice how the various elements are gradually brought in and blended automatically — this is the result of a dynamic vector. Now press the VECTOR PLAY [ON/OFF] key to turn the VECTOR PLAY mode ON, and select [LEVEL] control. Now set the [VECTOR CONTROL] to center position and play another note or chord. You should hear all 4 elements at the same time, in approximately equal proportions. Play with the [VECTOR CONTROL] a bit to get a feel for this particular combination of elements.

Now we'll go ahead and record an original dynamic level vector for the "Evolver" voice ...

1. The first step is to enter the VOICE VECTOR edit mode, which we do by pressing the [EDIT/UTILITY] key and then the [VOICE VECTOR] key (REFERENCE SECTION, page 36).

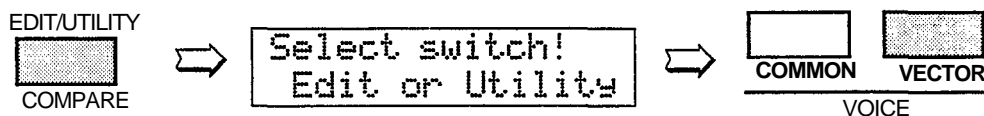

Please note that although the display directs you to the "Edit or Utility" switches after pressing the [EDIT/UTILITY] key, this refers to the VOICE, ELEMENT, MULTI, and UTILITY key groups located at the upper right-hand corner of the control panel. Pressing the [EDIT/UTILITY] key a second time has no effect.

2. If the LEVEL SPEED function does not appear immediately when you enter the VOICE VECTOR edit mode, press the [VOICE VECTOR] key a few times until it does appear (REFERENCE SECTION, page 37).

```

UU LEVEL SPEED
Vector Rate 30ms
  
```

Vectors are recorded by "sampling" the position of the [VECTOR CONTROL] at evenly-spaced steps. This function allows you to set the time between each sample step — i.e. the "Vector rate". Quite logically, short vector rates are best for quick control movements while longer vector rates are better for slow control movements. If you set the vector rate to too long a value for a rapid control movement, you may end up with a "jerky" sounding vector. The diagrams below show the same control movement recorded at 10-millisecond and 160-millisecond vector rates.

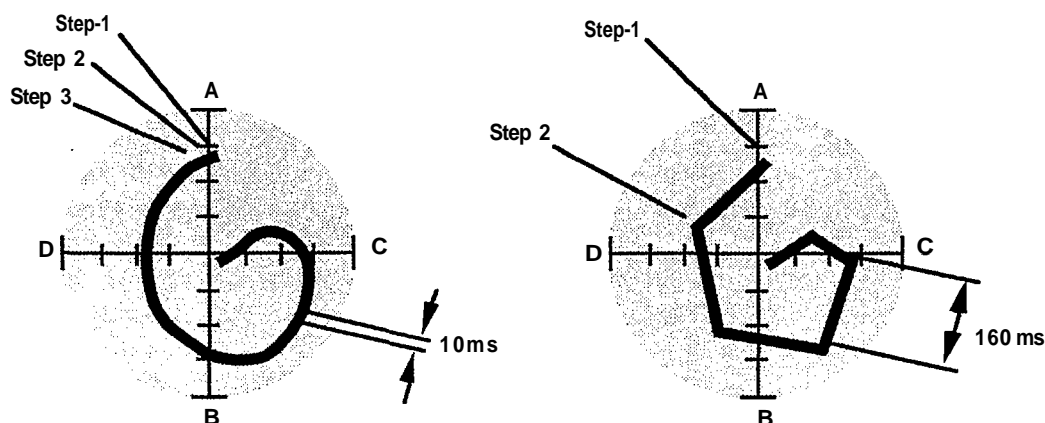

Move the cursor to the lower display line by pressing the [▷] cursor key, then use the [-1/NO] and [+1/YES] keys to set the vector rate parameter to "30ms." This is a fairly "average" vector rate, and is a good place to start experimenting with dynamic vectors.

```

UU LEVEL SPEED
Vector Rate 30ms
  
```

Please note that the LEVEL SPEED parameter can also be used to change the playback speed of pre-recorded vectors.

3. Press the [VOICE VECTOR] key once to move ahead to the LEVEL REC display (REFERENCE SECTION, page 37).

```
UU#LEVEL REC
  STBY REC PLAY
```

Use the [◀] and [▶] cursor keys to move the cursor to the STBY (standby) parameter. At this point the [VECTOR CONTROL] will be active in the level control mode, and you can rehearse the level vector you are about to record.

4. Move the cursor to the REC parameter. Vector recording will begin the instant you play a note on the keyboard. A rectangular block will flash at the cursor position while recording. Recording will end automatically when the maximum of 50 sampling steps has been reached — how long this takes depends both on the vector rate setting and how fast you move the [VECTOR CONTROL]. When recording finishes, the cursor will move automatically to the PLAY parameter position. At the same time the VECTOR PLAY mode will automatically be turned OFF so that the dynamic vector just recorded is active.

Now you can play on the keyboard to hear how your dynamic level vector turned out. If you don't like the results, simply move the cursor back to REC and record again.

Detune Vectors: Although you've just recorded a dynamic level vector, dynamic detune vectors can be recorded in exactly the same way using the DETUNE SPEED and DETUNE REC functions which are also accessible in the VOICE VECTOR edit mode (REFERENCE SECTION, page 39).

5. When you're satisfied with your first vector masterpiece, you can return to the VOICE PLAY mode with the option of storing the voice you have just edited into one of the SY22's INTERNAL memory locations.

There is, however, a slight catch. If you simply go ahead and attempt to store the voice at this point the SY22 will inform you that the internal memory is protected with a "Memory Protected" display, preventing the store operation. If this happens, you'll have to press the [-1/NO] key to exit from the "Memory Protected" display. Both INTERNAL and CARD memory protect functions are automatically activated whenever the SY22 is turned on, to prevent accidental erasure of important voices.

To turn the memory protect function off, press the [UTILITY SETUP] key a few times until the MEM. PROTECT function appears (REFERENCE SECTION, page 73).

```
SU#MEM. PROTECT
  INT=on  CARD=on
```

Move the cursor to the INT parameter and press the [-1/NO] or [+1/YES] key to turn the internal memory protection off.

6. Now press the [VOICE] key to return to the VOICE PLAY mode. Before actually returning you to the VOICE PLAY mode, however, the SY22 will ask you whether you want to store the voice you have just edited into one of the INTERNAL memory locations.

```
Store VOICE?  
Yes/No
```

You can skip this step and go straight to the VOICE PLAY mode by pressing the [-1/NO] key, or you can press [+1/YES] to initiate the voice storage procedure.

If you press [+1/YES], a display similar to the following will appear:

```
MEMORY STORE  
P47 → I_
```

The number of the voice you edited will be shown to the left of the lower display line, and the cursor will be placed to the right of the arrow. Select the memory location to which you want to store the new voice using the standard voice selection procedure.

```
MEMORY STORE  
P47 → I88 →
```

When the target memory location has been selected, press the [▷] cursor key. "Are you sure?" will appear on the display.

```
MEMORY STORE  
←Are you sure?
```

Confirm your intention to store the new voice by pressing the [+1/YES] key, and the store operation will begin. ">>Completed!!<<" will appear on the display briefly when the store operation is finished, and the SY22 will return to the VOICE PLAY mode.

The STORE Key

As we've just seen, the SY22 automatically gives you the option to store a voice you've just edited when you switch back to the VOICE play mode. You can also activate the store function to store the currently selected voice to a different INTERNAL or CARD memory location by pressing the [STORE] key while in the VOICE play mode. Likewise, the selected multi-play setup (REFERENCE section, page 59-61) can be stored to a different INTERNAL or CARD memory location by pressing the [STORE] key while in the MULTI play mode. In either case, the memory protect function for the memory to which you intend to store the voice or multi-play setup — INTERNAL or CARD — must first be turned OFF via the UTILITY mode MEMORY PROTECT function (REFERENCE section, page 73).

1. Turn the memory protect function for the INTERNAL or CARD memory off.
2. Select the VOICE or MULTI play mode, and select the voice or multi-play setup you want to store to a different memory location (P11 for this example).

3. Press the [STORE] key.

```
MEMORY STORE  
P11→I_
```

4. If necessary, select the destination memory by pressing the [INTERNAL] or [CARD] key, then enter the bank and number of the destination memory location (I36 for this example).

```
MEMORY STORE  
P11→I36 →
```

5. Press the PAGE [▷] key and the "Are you sure?" display will appear.

```
MEMORY STORE  
←Are you sure?
```

6. Press [+1/YES] to execute the store operation, or [-1/NO] to cancel. The store procedure can be exited at any time by pressing the [-1/NO] key.

Conclusion

You now have a edited version of "Evolver" featuring your own original dynamic level vector. You could use the VOICE COMMON edit mode NAME function (REFERENCE SECTION, page 31) to give the voice a new name — "Evolver2" for example. Using the same procedure you could create an infinite range of variations on the preset voices.

The method of dynamic vector recording just described is quick and easy — all you have to do is operate the [VECTOR CONTROL] and use your ears. This quick-and-easy method is recommended for most applications. If you want really fine control, however, the SY22 offers a number of level and detune vector editing functions that allow the position and length of each vector step to be precisely programmed as required. See pages 37 through 40 of the REFERENCE SECTION for details.

4. INSTANT VOICE PROGRAMMING

Although the SY22 allows you to program voices in considerable detail, in this section we'll present a simple way to create an unlimited range of new and useful voices.

Detailed parameters for programming individual elements are available in the ELEMENT TONE and ELEMENT ENVELOPE edit modes described in the REFERENCE SECTION, beginning on pages 41 and 51, respectively. Everything we need to have loads of fun — and to create some very serious voices — is available in the VOICE COMMON edit mode.

1. Select any preset voice while in the VOICE PLAY mode to serve as a "platform" for your new voice. "Evolver" (P84) is a good choice to start with.
2. Enter the VOICE COMMON edit mode by pressing the [EDIT/UTILITY] key and then the [VOICE COMMON] key (REFERENCE SECTION, page 30).

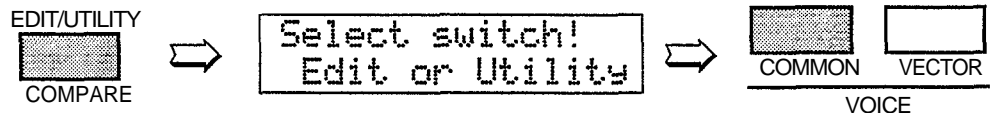

The VOICE COMMON edit mode provides access to the following functions, of which we're going to use just one!

NAME
CONFIGURATION
EFFECT TYPE
EFFECT DEPTH
PITCH BEND
WHEEL AMPLITUDE MODULATION
WHEEL PITCH MODULATION
AFTER TOUCH AMPLITUDE MODULATION
AFTER TOUCH PITCH MODULATION
AFTER TOUCH PITCH CONTROL
AFTER TOUCH LEVEL CONTROL
ENVELOPE ATTACK
ENVELOPE RELEASE
RANDOM ELEMENT
RANDOM LEVEL
RANDOM DETUNE

3. Press the [VOICE COMMON] key a few times until "RANDOM" appears on the top display line (REFERENCE SECTION, page 34). As long as the cursor is on the top display line next to the function name, it is also possible to scroll backward and forward through the function list by using the [-1/NO] and [+1/YES] key.

```
UC#RANDOM
ELEMENT
```

4. Use the [◀] and/or [▶] keys to move the cursor to the left-hand parameter on the lower display line (this will either be ELEMENT, LEVEL VEC, or DETUNE VEC) and, if necessary, select "ELEMENT" using the [-1/NO] and/or [+1/YES] keys.
5. Press the [▶] key once so that the cursor appears as a flashing block to the right of the "Y/N?" parameter.

```

VC RANDOM
ELEMENT  Y/N?
```

6. Now, each time you press the [+1/YES] key the SY22 will randomly assign different waveforms to the four elements in what used to be the Fanfare voice.
 Try it a few times: press [+1/YES] then play on the keyboard to hear a totally new voice. Since the element combinations are generated randomly, some are not particularly useful ... but others will surprise you. Every few tries you'll probably come up with a combination which, if not ready to use without further modification, can be turned into a very fine voice with a little "brushing up" in the various SY22 editing modes.
 Please note that the RANDOM ELEMENT function *only* replaces the element waveforms and LFO settings in the voice you started with, so, unless you go into further programming, the voice you choose as your platform will determine how controllers like the pitch and modulation wheels function (REFERENCE SECTION, page 32), the shape of the amplitude envelopes used for each element (REFERENCE SECTION, page 53), the type of effect (reverb, delay, etc.) applied to the voice (REFERENCE SECTION, page 31), and more.
7. While trying out the new voices you create, you can turn the VECTOR PLAY mode ON and experiment manually with different vectors. You can also enter the VOICE VECTOR mode by pressing the [VOICE VECTOR] key and record a dynamic vector as described in the previous section.
8. If you come up with something you want to keep, use the same voice store procedure as described on page 22 when returning the the VOICE PLAY mode.

Conclusion

You're now equipped to create a world of vibrant and very useful new voices with very little actual programming indeed. If you do want to get deep into the details and fine tune your voices until they are perfect, please take the time to read through the REFERENCE SECTION of this manual. In it, each editing function is described individually, often with a few helpful hints that will help you use it most effectively.



REFERENCE SECTION

VOICE COMMON

VOICE COMMON

The VOICE COMMON mode provides access to a range of parameters that affect the selected voice as a whole. Detailed programming of individual elements is provided by the ELEMENT TONE and ELEMENT ENVELOPE edit modes.

NAME	31
CONFIGURATION	31
EFFECT (Type & Depth)	31
PITCH BEND	32
WHEEL (Amplitude & Pitch Modulation)	32
AFTER TOUCH (Amplitude & Pitch Modulation, Pitch & Level Control)	33
ENVELOPE (Attack & Release Rates)	33
RANDOM (Element, Level & Detune)	34

VOICE COMMON

Selecting the VOICE COMMON Edit Mode

From the VOICE or MULTI mode:

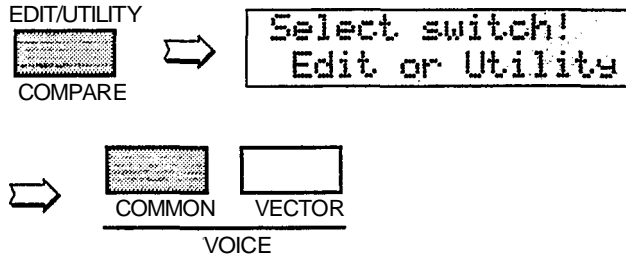

From another edit or utility mode simply press [VOICE COMMON].

An "E" will appear on the LED display, indicating that an edit mode has been selected. The dot to the right of the "E" will appear as soon as any parameter is edited.



Selecting the VOICE COMMON Edit Mode Functions

The various VOICE COMMON edit mode functions can be selected in sequence by pressing the [VOICE COMMON] key, or by using the [-1/NO] and [+1/YES] keys when the cursor (>) is located immediately before the function name on the upper display line.

The COMPARE Function

You can compare the sound of the edited voice with the sound of the voice before it was edited by pressing the [EDIT/COMPARE] key to activate the COMPARE function. A "C" will appear on the LED display while the COMPARE function is active, and the sound of the voice prior to editing will be heard when you play the keyboard. Press the [EDIT/COMPARE] key again to return to the edit mode.

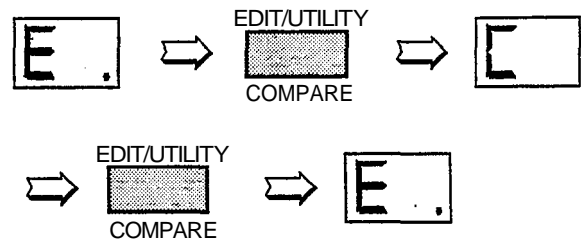

NAME

```
UC#VOICE NAME
I23 Initial
```

Summary: Assigns a name of up to 8 characters to the current voice.

Settings: The following characters are available for use in voice names:

```
(Space) !"#%&'(>)*+, -./0123456789:;<=>?@
ABCDEFGHIJKLMNPOQRSTUVWXYZ[\]^_`
abcdefghijklmnopqrstuvwxyz{|}~*
```

Procedure: Use the [◀] and [▶] cursor keys to place the underline cursor under the character to be changed. Use the [-1/NO] and [+1/YES] keys to select the desired character. Continue until the entire voice name has been programmed.

Details: It's a good idea to give your voices names that make them easily identifiable. If you've created a new voice that combines piano and organ elements, for example, you could call it something like "PianOrg".

When selecting characters, scrolling will pause at the beginning of each character group (capitals, lower case, numbers, and symbols).

Refer to: Tutorial, page 24.

CONFIGURATION

```
UC#CONFIGURATION
A-B-C-D
```

Summary: Selects the two-element (A-B) or four-element (A-B-C-D) voice configuration.

Settings: A-B, A-B-C-D

Procedure: Use the [▶] key to move the cursor to the lower display line. Use the [-1/NO] and [+1/YES] keys to select the desired configuration.

Details: In the 2-element "A-B" configuration, element A is AWM and element B is FM. In the 4-element "A-B-C-D" configuration elements A and B are the same as in the "A-B" configuration, while element C is AWM and element D is FM.

A-B: A = AWM, B = FM.

A-B-C-D: A = AWM, B = FM, C = AWM, D = FM.

Refer to: Tutorial, page 14.

EFFECT (Type & Depth)

```
UC#VOICE EFFECT
Rev Hall Def=1
```

Summary: Selects one of sixteen digital effects, and sets the depth of the selected effect for the current voice.

VOICE COMMON

Settings: Effect type:

Rev Hall	(Reverb Hall)
Rev Room	(Reverb Room)
Rev Plate	(Reverb Plate)
Rev Club	(Reverb Club)
Rev Metal	(Reverb Metal)
Delay 1	(Short Single Delay)
Delay 2	(Long Delay)
Delay 3	(Long Delay)
Doubler	(Doubler)
Ping-Pong	(Ping Pong Delay)
Pan Ref	(Panned Reflections)
Early Ref	(Early Reflections)
Gate Rev	(Gated Reverb)
Dly&Rev 1	(Delay & Reverb 1)
Dly&Rev 2	(Delay & Reverb 2)
Dist&Rev	(Distortion & Reverb)

Depth: 0...7

Procedure: Use the [◀] and [▶] cursor keys to place the underline cursor under the effect type or depth parameter. Use the [-1/NO] and [+1/YES] keys to select the desired effect or effect depth.

Details: Setting the depth parameter to "0" is equivalent to turning the effect OFF. A depth setting of "7" produces the greatest effect.

Refer to: Tutorial, page 13,16-19.

PITCH BEND

```
UC▶PITCH BEND
Range= 2 .
```

Summary: Sets the range of the pitch bend wheel.

Settings: 0 ... 12 max.*

Procedure: Use the [▶] key to move the cursor to the lower display line. Use the [-1/NO] and [+1/YES] keys to select the desired pitch bend range.

Details: Each increment from "0" to "12" represents a semitone. A setting of "0" produces no pitch bend. A setting of "12" allows a maximum pitch bend of plus or minus one octave, while a setting of "4" allows a maximum pitch bend of plus or minus a major third.

Refer to: Page 3.

* This range may be more limited in some cases. An exclamation mark (!) will appear after the range value when the limit is reached.

WHEEL (Amplitude & Pitch Modulation)

```
UC▶WHEEL
AM=on PM=on
```

Summary: Assigns the modulation wheel to amplitude and/or pitch modulation.

Settings: AM (Amplitude Modulation): off, on
PM (Pitch Modulation): off, on

Procedure: Use the [◀] and [▶] cursor keys to place the underline cursor under the AM or PM parameter. Use the [-1/NO] and [+1/YES] keys to turn the selected parameter on or off.

Details: Amplitude modulation produces a *tremolo* effect while pitch modulation produced a *vibrato* effect. This function allows the modulation wheel

to be assigned to produce either or both. This is only an "off/on" switch, however, and the maximum depth of modulation to be applied must be set using the LFO AM Depth and PM Depth parameters in the ELEMENT TONE edit mode. When the modulation wheel is assigned to amplitude or pitch modulation, LFO modulation can *only* be applied via the wheel. If both WHEEL and AFTER TOUCH are assigned to modulation control, the controller via which the highest modulation level is applied will take priority when both are used simultaneously.

Refer to: Page 3.

AFTER TOUCH (Amplitude & Pitch Modulation, Pitch & Level Control)

```
UC#AFTER TOUCH
AM=on PM=on →
```

Summary: Assigns keyboard after-touch to amplitude modulation, pitch modulation, pitch control, or level control — or any combination of the above.

Settings: AM (Amplitude Modulation): off, on
 PM (Pitch Modulation): off, on
 Pit (Pitch Control): -12 ... 0 ... +12 max.*
 Lev (Level Control): off, on

Procedure: Use the [◀] and [▶] cursor keys to place the underline cursor under the AM, PM, Pit, or Lev parameter. The arrows at either end of the display mean that more parameters can be accessed by scrolling in the indicated direction. Use the [-1/NO] and [+1/YES] keys to turn the AM, PM, and/or Lev parameter on or off, or to select the desired Pit control range.

Details: As with the modulation wheel, amplitude modulation produces a *tremolo* effect while pitch modulation produced a *vibrato* effect. The harder you press a key, the deeper the modulation. This is only an "off/on" switch, however, and the maximum depth of modulation to be applied must be set using the LFO AM Depth and PM Depth parameters in the ELEMENT TONE edit mode.

When after touch is assigned to amplitude or pitch modulation, LFO modulation can *only* be applied via after touch.

The Pit parameter allows keyboard after touch to be used for note bending. The greater the key pressure the greater the amount of pitch bend. Positive values produce an upward bend when key pressure is applied, and minus values produce a downward bend. Each increment from represents a semitone. A setting of "0" produces no pitch bend. A setting of "12" allows a maximum upward pitch bend of one octave, while a setting of "-4" allows a maximum downward pitch bend of a major third.

When the Lev parameter is turned on it becomes possible to control the level of the sound over a limited range by keyboard after touch. The amount and direction (i.e. an increase or decrease) of level change depends on the setting of the AFTER TOUCH SENSITIVITY parameter in the ELEMENT TONE edit mode.

If both WHEEL and AFTER TOUCH are assigned to modulation control, the controller via which the highest modulation level is applied will take priority when both are used simultaneously.

* This range may be more limited in some cases. An exclamation mark (!) will appear after the range value when the limit is reached.

ENVELOPE (Attack & Release Rates)

```
UC#ENVELOPE
AR= 0 RR= 0
```

Summary: Sets the overall attack and release rates for the current voice.

Settings: AR (Attack Rate): -99 ... 0 ... +99 max.*
 RR (Release Rate): -99 ... 0 ... +99 max.*

Procedure: Use the [◀] and [▶] cursor keys to place the underline cursor under the AR or RR parameter. Use the [-1/NO] and [+1/YES] keys to set the selected parameter as required.

Details: Although much more detailed envelope programming capability is available for individual elements (see the ELEMENT ENVELOPE edit mode), these functions provide an easy way to adjust the most important envelope parameters for the overall voice. Positive values produce a faster attack or release time, while negative values produce a slower attack or release time. You might want to lengthen the release time of a voice, for example, to produce a lingering sustain effect after you release the keys.

VOICE COMMON

Please note that the AR parameter will have no effect on elements in which the INITIAL LEVEL parameter (page 54) is set to 99.

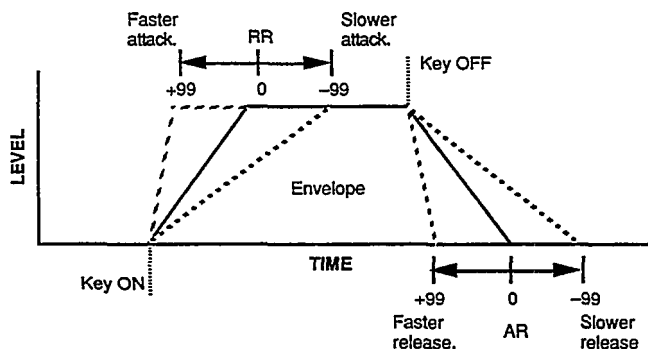

Refer to: ELEMENT ENVELOPE section page 53-57.

- * This range may be more limited in some cases. An exclamation mark (!) will appear after the range value when the limit is reached.

RANDOM (Element, Level & Detune)

UC▶RANDOM
ELEMENT

Summary: Automatically produces random combinations of elements, level vectors, or detune vectors.

Settings: None.

Procedure: Use the [\leftarrow] and [\rightarrow] cursor keys to place the underline cursor under the left parameter on the lower display line, then use the [-1 /NO] and [$+1$ /YES] keys to select ELEMENT, LEVEL or DETUNE. Press the [\rightarrow] to move the cursor to "Y/N," then press the [$+1$ /YES] key to generate random values of the select type. A new set of random values is generated each time the [$+1$ /YES] key is pressed while the cursor is in this position. Pressing the [-1 /NO] returns the cursor to the left parameter.

Details: This function is actually a very useful programming aid. It allows you try out a virtually unlimited variety of element combinations or level/detune vectors by simply pressing a single key. The random element combinations, in particular, can produce some very surprising and often pleasant results.

When the "A-B" voice configuration is selected (see CONFIGURATION on page 31), random element combinations will always consist of only two elements. When the "A-B-C-D" voice configuration is selected, random element generation will produce combinations of four elements.

Refer to: Tutorial, page 25.

VOICE VECTOR

The VOICE VECTOR edit mode allows recording and fine editing of dynamic level and detune vectors.

LEVEL SPEED (Vector Rate).....	37
LEVEL RECORD	37
LEVEL EDIT (Step, X-axis, Y-axis & Time)	37
DETUNE SPEED (Vector Rate)	39
DETUNE RECORD	39
DETUNE EDIT (Step, X-axis, Y-axis & Time).....	39

VOICE VECTOR

Selecting the VOICE VECTOR Edit Mode

From the VOICE or MULTI mode:

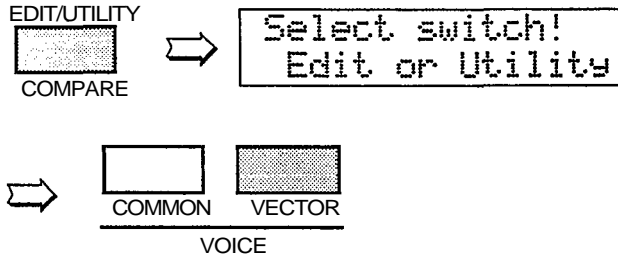

From another edit or utility mode simply press [VOICE VECTOR].

An "E" will appear on the LED display, indicating that an edit mode has been selected. The dot to the right of the "E" will appear as soon as any parameter is edited.



Selecting the VOICE VECTOR Edit Mode Functions

The various VOICE VECTOR edit mode functions can be selected in sequence by pressing the [VOICE VECTOR] key, or by using the [-1/NO] and [+1/YES] keys when the cursor (>) is located immediately before the function name on the upper display line.

The COMPARE Function

You can compare the sound of the edited voice with the sound of the voice before it was edited by pressing the [EDIT/COMPARE] key to activate the COMPARE function. A "C" will appear on the LED display while the COMPARE function is active, and the sound of the voice prior to editing will be heard when you play the keyboard. Press the [EDIT/COMPARE] key again to return to the edit mode.

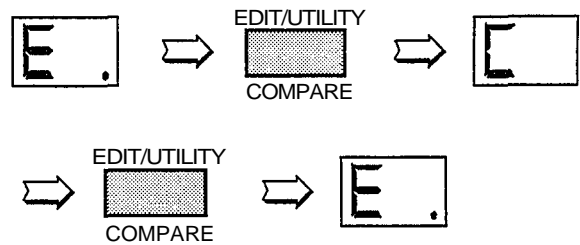

LEVEL SPEED (Vector Rate)

```
UV▶LEVEL SPEED
Vector Rate 30ms
```

Summary: Sets the time between level vector steps.

Settings: 10 ... 160 milliseconds (in 10-millisecond steps)

Procedure: Use the [▷] key to move the cursor to the lower display line. Use the [-1/NO] and [+1/YES] keys to select the desired vector rate.

Details: Each dynamic vector is composed of up to 50 "steps" corresponding to points along the

path followed by the vector control. This function sets the initial time between each step. The Time parameter in the LEVEL EDIT function, described later, allows the length of individual steps to be edited. The vector rate parameter can be changed even after recording a vector, producing a corresponding change in the spacing between the steps.

The LEVEL SPEED parameter can also be used to change the playback speed of a pre-recorded vector.

Refer to: Tutorial, page 21.

LEVEL RECORD

```
UV▶LEVEL REC
STBY REC PLAY
```

Summary: Allows recording of a dynamic level vector.

Settings: STBY, REC, PLAY

Procedure: Use the [◀] and [▷] cursor keys to place the underline cursor under STBY. The vector control LEVEL mode will be automatically selected and you can rehearse the vector sweep you wish to record.

Move the cursor to REC. Recording will actually

begin as soon as you play a key on the keyboard. When you release the key or when 50 steps have been recorded (See "LEVEL SPEED" above), recording will end and the cursor will move to the PLAY position. You can now play the keyboard to hear how the vector sweep you just recorded sounds.

Details: The amount of time available for recording depends both on the vector rate setting and how much the vector control is moved.

Refer to: Tutorial, page 22.

LEVEL EDIT (Step, X-axis, Y-axis & Time)

● Step

```
UV L.ED A▬B▬C▬D▬
1 X 0 Y 0 End
```

Summary: Selects any of the 50 steps in a recorded level vector for editing.

Settings: 1 ... 50

Procedure: Use the [◀] and [▷] cursor keys to place the underline cursor under the leftmost value on the lower display line (Step). Use the [-1/NO] and [+1/YES] keys to select the step to be edited.

VOICE VECTOR

Details: Step 1 is the first step recorded and step 50 is the last. Experience will give you a feel for relating specific points in a dynamic vector to the corresponding steps.

Refer to: Tutorial, page 21-24.

● X-axis & Y-axis

```
UV L.ED A B C D
1 X 0 Y 0 End
```

Summary: These parameters define the position of the currently selected step on the X and Y axes of the level vector control range.

Settings: -31 ... 0 ... +31

Procedure: After selecting the step to be recorded as described in the previous function, use the [◀] and [▶] cursor keys to place the underline cursor under the X or Y parameter. Use the [-1/NO] and [+1/YES] keys to set the value as required.

Details: On the X (D-C) axis, a setting of -31 places the step as far as possible toward the D element while a setting of +31 places it as far as possible toward the C element. The Y (A-B) axis values work in the same way: a setting of -31 places the step as far as possible toward the B element while a setting of +31 places it as far as possible toward the A element. In both axes a setting of 0 places the step at center position.

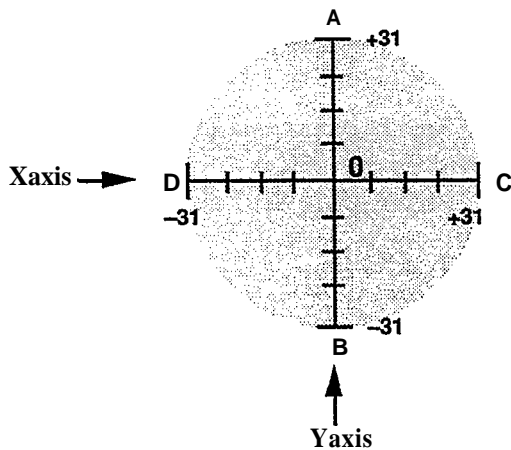

Refer to: Tutorial, page 21-24.

● Time

```
UV L.ED A B C D
1 X 0 Y 0 End
```

Summary: Multiplies the vector rate setting of the current level vector step only. Also allows vectors to be looped or ended at the current step.

Settings: 1 ... 254, Repeat, End

Procedure: Use the [◀] and [▶] cursor keys to place the underline cursor under the rightmost value on the lower display line (Time). Use the [-1/NO] and [+1/YES] keys to select the required time value, repeat, or end.

Details: Time values multiply the vector rate setting for the current step. If the vector rate parameter is set to 30ms, for example, setting the time parameter to 2 results in a step length of 60ms, setting it to 3 results in a step length of 90ms, and so on. Since the maximum time value is 254, extremely long steps can be created. If you select the "End" setting, the vector will end at the current step. The "Repeat" setting causes the vector to loop back to the first step from the current step, repeating continuously.

Refer to: Tutorial, page 21-24.

DETUNE SPEED (Vector rate)

```
UU▶DETUNE SPEED
  Vector Rate 30ms
```

Summary: Sets the time between detune vector steps.

Settings: 10 ... 160 milliseconds

Procedure: Use the [▶] key to move the cursor to the lower display line. Use the [-1/NO] and [+1/YES] keys to select the desired vector rate.

Details: Each automatic vector sweep is composed of up to 50 "steps," corresponding to equally-spaced points along the path followed by the vector control. This function sets the initial time between each step.

Refer to: Tutorial, page 22.

DETUNE RECORD

```
UU▶DETUNE REC
  STBY REC PLAY
```

Summary: Allows recording of a dynamic detune vector.

Settings: STBY, REC, PLAY

Procedure: Use the [◀] and [▶] cursor keys to place the underline cursor under STBY. The vector control DETUNE mode will be automatically selected and you can rehearse the vector sweep you wish to record.
Move the cursor to REC. Recording will actually begin as soon as you play a key on the key

board. When you release the key or when all 50 steps have been recorded (See "DETUNE SPEED" above), recording will end and the cursor will move to the PLAY position. You can now play the keyboard to hear how the vector sweep you just recorded sounds.

Details: The amount of time available for recording depends both on the vector rate setting and how much the vector control is moved.

Moving the vector control towards an element raises the pitch of that element while lowering the pitch of the others.

Refer to: Tutorial, page 22.

DETUNE EDIT (Step, X-axis, Y-axis & Time)

● Step

```
UU D.ED A#B#C#D#
  1 X 0 Y 0 End
```

Summary: Selects any of the 50 steps in a recorded detune vector for editing.

Settings: 1 ... 50

Procedure: Use the [◀] and [▶] cursor keys to place the underline cursor under the leftmost

value on the lower display line (Step). Use the [-1/NO] and [+1/YES] keys to select the step to be edited.

Details: Step 1 is the first step recorded and step 50 is the last. Experience will give you a feel for relating specific points in a dynamic vector to the corresponding steps.

Refer to: Tutorial, page 21-24.

VOICE VECTOR

● X-axis & Y-axis

```
UV D.ED A B C D
1 X 0 Y 0 End
```

Summary: These parameters define the position of the currently selected step on the X and Y axes of the detune vector control range.

Settings: -31 ... 0 ... +31

Procedure: Use the [◀] and [▶] cursor keys to place the underline cursor under the X or Y parameter. Use the [-1/NO] and [+1/YES] keys to set the value as required.

Details: On the X (D-C) axis, a setting of -31 places the step as far as possible toward the D element while a setting of +31 places it as far as possible toward the C element. The Y (A-B) axis values work in the same way: a setting of -31 places the step as far as possible toward the B element while a setting of +31 places it as far as possible toward the A element. In both axes a setting of 0 places the step at center position.

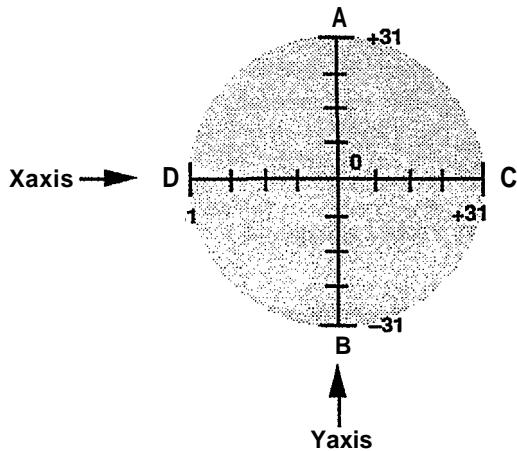

Refer to: Tutorial, page 21-24.

● Time

```
UV D.ED A B C D
1 X 0 Y 0 End
```

Summary: Multiplies the vector rate setting of the current detune vector step only. Also allows vectors to be looped or ended at the current step.

Settings: 1 ... 254, Repeat, End

Procedure: Use the [◀] and [▶] cursor keys to place the underline cursor under the rightmost value on the lower display line (Time). Use the [-1/NO] and [+1/YES] keys to select the required time value.

Details: Time values multiply the vector rate setting for the current step. If the vector rate parameter is set to 30ms, for example, setting the time parameter to 2 results in a step length of 60ms, setting it to 3 results in a step length of 90ms, and so on. Since the maximum time value is 254, extremely long steps can be created. If you select the "End" setting, the vector will end at the current step. The "Repeat" setting causes the vector to loop back to the first step from the current step, repeating continuously.

Refer to: Tutorial, page 21-24.

ELEMENT TONE

The ELEMENT TONE edit mode allows editing many of the most important sound-determining parameters of each individual element — A and B in a 2-element voice; A, B, C and D in a 4-element voice.

WAVE TYPE	43
ELEMENT COPY	45
FREQUENCY SHIFT	45*
VOLUME	46
PAN	46*
VELOCITY SENSITIVITY	46
AFTER TOUCH SENSITIVITY	47
TONE (FM Elements B and D Only)	47*
LFO (Low Frequency Oscillator) AM Depth, PM Depth, Type, Delay, Rate & Speed	48*

* These four parameters are not available for an AWM element in which wave number 127 (Drum Set) is selected — "Cannot edit" display appears.

ELEMENT TONE

Selecting the ELEMENT TONE Edit Mode

From the VOICE or MULTI mode:

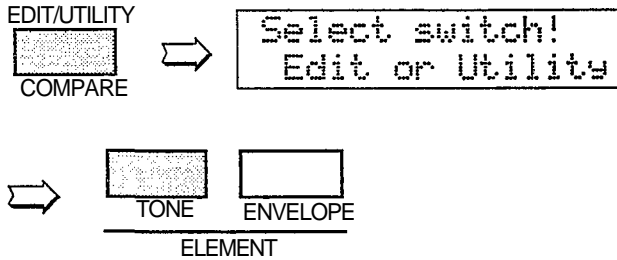

From another edit or utility mode simply press [ELEMENT TONE].

An "E" will appear to the left of the LED display to indicate that an edit mode is selected, and the element selected for editing will be displayed to the right of the display — "A", "b", "C", or "d". A dot will appear to the right of the element character as soon as any parameter has been edited.

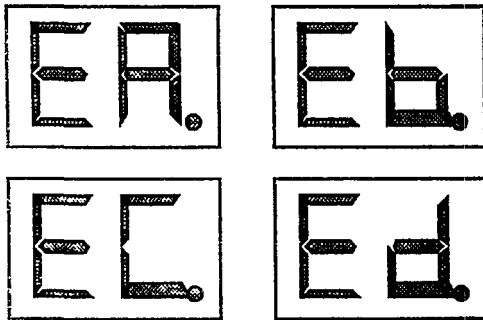

Different elements can be selected for editing by pressing the appropriate [ELEMENT SELECT] key — [A], [B], [C] or [D]. If a 2-element voice is being edited, only elements A and B can be selected.

Any of the available elements can also be turned on or off by pressing the appropriate [ELEMENT ON/OFF] key. Each key alternately turns the associated element on and off, and the on/off status of the elements is shown to the right of the upper LCD line. If the element character is showing, the associated element is ON, if a cash appears in place of the element

character, that element is OFF. The ability to turn elements on or off while editing makes it easier to hear the effect of parameter changes on a single element. The currently selected element is also shown on the LCD as a reversed (white on black) character.

In this example elements A, B and D are ON, while element C is OFF. Element A is currently selected for editing.

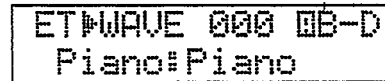

Selecting the ELEMENT TONE Edit Mode Functions

The various ELEMENT TONE edit mode functions can be selected in sequence by pressing the [ELEMENT TONE] key, or by using the [-1/NO] and [+1/YES] keys when the cursor (▷) is located immediately before the function name on the upper display line.

The COMPARE Function

You can compare the sound of the edited voice with the sound of the voice before it was edited by pressing the [EDIT/COMPARE] key to activate the COMPARE function. A "C" will appear on the LED display while the COMPARE function is active, and the sound of the voice prior to editing will be heard when you play the keyboard. Press the [EDIT/COMPARE] key again to return to the edit mode.

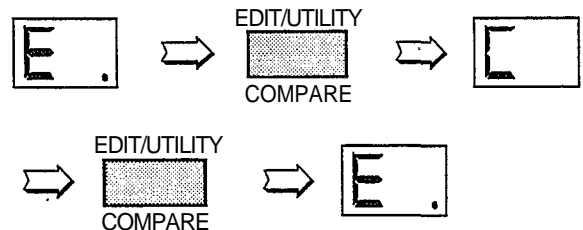

WAVE TYPE

```
ET WAVE 000 0BCD
Piano:Piano
```

Summary: Assigns a preset wave to the selected element.

Settings: Elements A and C (AWM): 0 ... 127
Elements B and D (FM): 0 ... 255

Procedure: Use the [◀] and [▶] cursor keys to place the underline cursor under the left

parameter on the lower display line to directly select the different wave categories, or under the right parameter to select individual waves. Use the [-1/NO] and [+1/YES] keys to select the desired wave (refer to the wave list, below).

Details: The number of waves available depends on whether the currently selected element is an AWM element (A or C) or an FM element (C or D). The SY22 has 128 preset AWM waves (0 ... 127) and 256 preset FM waves (0 ... 255).

AWM WAVEFORM LIST

Category	No.	Name	Category	No.	Name	Category	No.	Name	Category	No.	Name	
Piano	0	Piano	Bass	32	E.Bass 3	Synth	64	Oh Hit	OSC	96	Padwv	
	1	E.piano		33	E.Bass 4		SFX	65		Water 1	97	Digital1
	2	Clavi		34	Slap			66		Water 2	98	Digital2
	3	Cembalo		35	Fretless			67		Stream	99	Digital3
4	Celesta	36	SynBass1	68	Coin	100		Digital4				
Organ	5	P.organ	Str.	37	SynBass2	Hits	69	Crash	SEQ	101	Digital5	
	6	E.organ1		38	Strings		70	Bottle		102	Saw1	
	7	E.organ2		39	Vn.Ens.		71	Tear		103	Saw 2	
	8	Reed		40	Cello		72	Cracker		104	Saw 3	
Brass	9-15	Trumpet Mute Trp Trombone Flugel Fr Horn BrasAtak SynBrass	Vocal	41	Pizz.	Tran.	73	Scratch	105	Saw 4		
				42	Syn Str		74	Metal 1	106	Square 1		
				43	Choir		75	Metal 2	107	Square 2		
				44	Itopia		76	Metal 3	108	Square 3		
				45	Ooo!		77	Metal 4	109	Square 4		
Wood	16-19	Flute Clarinet Oboe Sax	Perc.	46	Vibes	OSC	78	Wood	110	Pulse 1		
				47	Marimba		79	Bamboo	111	Pulse 2		
				48	Bells		80	Slam	112	Pulse 3		
				49	Timpani		81	Tp.Body	113	Pulse 4		
				50	Tom		82	Tb. Body	114	Pulse 5		
Gtr	20-27	Gut Steel E.Gtr 1 E.Gtr2 Mute Gtr Sitar Pluck 1 Pluck 2	Synth	51	E.Tom	Tran.	83	HornBody	115	Pulse 6		
				52	Cuica		84	Fl.Body	116	Tri		
				53	Whistle		85	Str.Body	117	Sin8'		
				54	Claps		86	AirBlown	118	Sin8'+4'		
				55	Hit		87	Reverse1	SEQ	119	SEQ1	
				56	Harmonic		88	Reverse2		120	SEQ 2	
				57	Mix		89	Reverse3		121	SEQ 3	
				58	Sync		OSC	90		EPwv	122	SEQ 4
59	Bell Mix	91	Organ wv	123	SEQ 5							
60	Styroll	92	M.Tpwv	124	SEQ 6							
61	DigiAtak	93	Gtrwv	125	SEQ 7							
Bass	28-31	Wood B 1 Wood B 2 E.Bass 1 E.Bass 2	Synth	62	Noise 1	Drum	94	Strwv1	126	SEQ 8		
				63	Noise 2		95	Strwv2	Drum set			

AWM Waveform Category Descriptions

Piano	Piano, clavi, and other decay-type keyboard sounds.	Synth	A range of synth sounds (including noise).
Organ	Pipe, electric and reed organs.	SFX	Special effects - water, bottles, etc.
Brass	Acoustic and synthesized brass sounds.	Hits	Struck metal and woods.
Wood	Flute, sax and other woodwind sounds.	Tran.	Transient attack waves and some reverse sounds.
Gtr	Acoustic and electric guitars.	OSC	Standard synth waveforms and the basic waveforms from some actual instruments.
Bass	Acoustic, electric, and synth bass.	SEQ	Sequences of sampled sounds.
Str.	Violin ensemble and other strings.	Drum	Drum set waves.
Vocal	Choir and other vocal-type sounds.		
Perc.	Vibes, tympani, etc.		

ELEMENT TONE

FM VOICE LIST

Category	No.	Name	Category	No.	Name	Category	No.	Name	Category	No.	Name	
Piano	0	E.Piano1	Pluck	49	Guitar 4	Syn.S	98	Sus.1	SFX	147	SFX 5	
	1	E.Piano2		50	Guitar 5		99	Sus.2		148	SFX 6	
	2	E.Piano3		51	Guitar 6		100	Sus.3		149	SFX 7	
	3	E.Piano4		52	Guitar 7		101	Sus.4		OSC1	150	Sin 16'
	4	E.Piano5		53	Guitar 8		102	Sus.5			151	Sin 8'
5	E.Piano6	Bass	54	Bass1	103	Sus.6	152	Sin 4'				
Organ	6		E.organ1	55	Bass 2	104	Sus.7	153	Sin2 2/3			
	7		E.organ2	56	Bass 3	105	Sus.8	154	Sin2'			
	8		E.organ3	57	Bass 4	106	Sus.9	155	Saw1			
	9		E.organ4	58	Bass 5	107	Sus.10	156	Saw 2			
	10	E.organ5	59	Bass 6	108	Sus.11	157	Square				
	11	E.organ6	60	Bass 7	109	Sus.12	158	LFOnoise				
	12	E.organ7	61	Bass 8	110	Sus.13	159	Noise 1				
	13	E.organ8	62	Bass 9	111	Sus.14	160	Noise 2				
Brass	14	Brass 1	Str.	63	Str1	Syn.M	112	Sus.15	OSC2	161	Digi1	
	15	Brass 2		64	Str 2		113	Attack 1		162	Digi2	
	16	Brass 3		65	Str 3		114	Attack 2		163	Digi3	
	17	Brass 4		66	Str 4		115	Attack 3		164	Digi 4	
	18	Brass 5		67	Str 5		116	Attack 4		165	Digi5	
	19	Brass 6		68	Str 6		117	Attack 5		166	Digi 6	
	20	Brass 7		Perc.	70		Vibes 1	118		Move1	167	Digi7
	21	Brass 8	71		Vibes 2	119	Move 2	168	Digi 8			
	22	Brass 9	72		Vibes 3	120	Move 3	169	Digi9			
	23	Brass 10	73		Vibes 4	121	Move 4	170	Digi 10			
	24	Brass 11	74		Marimba1	122	Move 5	171	Digi 11			
	25	Brass 12	75		Marimba2	123	Move 6	OSC3	172	wave1-1		
	26	Brass 13	76		Marimba3	124	Move 7		173	wave1-2		
	Wood	28	Wood1	Syn.D	77	Bells 1	125		Decay 1	174	wave1-3	
29		Wood 2	78		Bells 2	126	Decay 2		175	wave2-1		
30		Wood 3	79		Bells 3	127	Decay 3		176	wave2-2		
31		Wood4	80		Bells 4	128	Decay 4	177	wave2-3			
32		Wood5	81		Bells 5	129	Decay 5	:	:			
33		Wood6	82		Bells 6	130	Decay 6	220	wave17-1			
34		Wood 7	83		Bells 7	131	Decay 7	221	wave17-2			
35		Wood 8	84		Bells 8	132	Decay 8	222	wave17-3			
Reed	36	Reed1	Syn.S	85	Metal 1	133	Decay 9	OSC3	223	wave18-1		
	37	Reed 2		86	Metal 2	134	Decay 10		224	wave18-2		
	38	Reed 3		87	Metal 3	135	Decay 11		225	wave18-3		
	39	Reed 4		88	Metal 4	136	Decay 12		:	:		
	40	Reed5		89	Metal 5	137	Decay 13		250	wave27-1		
	41	Reed 6		90	Metal 6	138	Decay 14		251	wave27-2		
Pluck	42	Clavi 1	Syn.S	91	Lead1	139	Decay 15	SFX	252	wave27-3		
	43	Clavi 2		92	Lead 2	140	Decay 16		253	wave28		
	44	Clavi 3		93	Lead 3	141	Decay 17		254	wave29		
	45	Clavi 4		94	Lead 4	142	Decay 18		255	wave30		
	46	Guitar 1		95	Lead 5	143	SFX1					
	47	Guitar 2		96	Lead 6	144	SFX 2					
	48	Guitar 3		97	Lead 7	145	SFX 3					
						146	SFX 4					

FM Voice Category Descriptions

Piano	Electric pianos.	Perc.	Vibes, marimba, bells and other percussion sounds.
Organ	Electric organs.	Syn.S	Sustained lead synth sounds.
Brass	A variety of brass sounds.	Syn.M	Synth sounds that vary with time.
Wood	Woodwind instrument sounds.	Syn.D	Decay-type synth sounds.
Reed	Sax, oboe and other reed instruments.	SFX	A range of sound-effect type synth sounds.
Pluck	Guitar, clavi, and other plucked instrument sounds.	OSC1	Sine, sawtooth, and other standard synth waveforms.
Bass	Bass sounds.	OSC2	Basic FM timbres, group 1.
Str.	Strings.	OSC3	Basic FM timbres, group 2.

If the TYPE parameter in the ELEMENT ENVELOPE edit mode (page 53) is set to PRESET, selecting a WAVE TYPE also selects the corresponding preset envelope. If a different

envelope type is selected, the preset envelope is *not* selected together with the wave.

Refer to: Tutorial, page 14,16-19.

ELEMENT COPY

```
ET#COPYfrom [BCD
any Voice? →
```

Summary: Copies all element parameters from an element of the same type (AWM or FM) in another voice to the current element of the current voice.

Settings: Source: I, C, P
Bank: 1 ... 8
Number: 1 ... 8
Element: A/C or B/D

Procedure: Use the [◀] and [▶] cursor keys to move the cursor to the source, bank, or number of the source voice (the voice from which the element parameters are to be copied) to the left of the lower display line. Use the [-1/NO] and [+1/YES] keys to set the selected parameter as necessary.

Next move the cursor to the element type parameter to the right of the lower display line, and select the element from which the data is to be copied using the [-1/NO] and [+1/YES] keys.

Press the [▶] cursor key one more time and the "Are you sure?" display will appear. Press [+1/YES] to execute the element copy operation or [-1/NO] to cancel. "»Completed!!«" will appear briefly when the copy operation has finished.

Details: In this display the source, bank and number parameters are shown in the standard SY22 voice number format. "P12," for example, is preset bank 1, number 2; "I35" is internal bank 3, number 5, etc.

Data can only be copied between elements of the same type. If the element currently being edited is an AWM element (A or C), only element A or C of the source voice can be copied from. the same applies to FM elements.

The data for all parameters contained in the ELEMENT TONE mode will be copied.

FREQUENCY SHIFT

```
ET#FREQ. [BCD
Shift= 0
```

Summary: Shifts the frequency (pitch) of the selected element up or down in semitone steps.

Settings:-12 ...0...+12.

Procedure: Use the [▶] key to move the cursor to the lower display line. Use the [-1/NO] and [+1/YES] keys to select the desired amount of frequency shift.

Details: A setting of "-12," for example, shifts the pitch of the selected element down by one octave; a setting of "+4" shifts the pitch up by a major third.

The Frequency Shift function can be used to transpose an element to its most useful range, or to create harmony (intervals) between different elements.

VOLUME

```
ET*VOLUME  BCD
Level= 0
```

Summary: Adjusts the volume of the selected element.

Settings: 0... 99

Procedure: Use the [▷] key to move the cursor to the lower display line. Use the [-1/NO] and

[+1/YES] keys to select the desired volume level.

Details: A setting of "0" produces no sound while a setting of "99" produces maximum volume. The ability to independently adjust the volume of each element makes it simple to set up the optimum balance or "mix" between elements.

PAN

```
ET*PAN      BCD
L--I--R
```

Summary: Determines the position in the stereo sound field in which the sound from selected element will be heard (left to right).

Settings: Graphic Display: L--+R, 5 positions from left to right.

Procedure: Use the [▷] key to move the cursor to the lower display line. Use the [-1/NO] and [+1/YES] keys to select the desired pan position.

Details: The lower line of the display shows a graphic representation of the stereo sound field with "L" representing "left" and "R" representing "right." As you edit the pan parameter the position indicator will appear at the corresponding position on the graphic display. A total of five different positions are available, corresponding to left, left-center, center, right-center, and right.

Interesting stereo effects can be produced by placing the output from different elements at different locations in the stereo sound field.

VELOCITY SENSITIVITY

```
ET*VELOCITY BCD
Sense= 0  ---
```

Summary: Determines how the output level of the selected element changes in response to velocity changes (keyboard initial touch response).

Settings: -5 ...0...+5

Procedure: Use the [▷] key to move the cursor to the lower display line. Use the [-1/NO] and [+1/YES] keys to select the desired velocity sensitivity.

Details: Plus "+" settings produce higher output level in response to higher velocity values — i.e. the harder a key is played, the louder the sound. Minus "-" settings produce the opposite effect: lower level in response to higher velocity. A setting of "0" results in no level variation.

0 No response.

+1 Narrow change between medium-hard and hard velocity.

- +2 Broader change between medium and hard velocity.
- +3 Smooth change all the way from soft to hard velocity.
- +4 Large change over small velocity range.
- +5 Sudden change from no sound to maximum level at about medium velocity.

"-" Settings have the same effect, but the sound level decreases rather than increasing with increased key velocity. A graphic display to the right of the sensitivity value provides a visual indication as to the type of change produced by each setting.

AFTER TOUCH SENSITIVITY

```
ET▶AFTER  ABCD
Sense= 0  ---
```

Summary: Determines how the output level of the selected element changes in response to keyboard after touch pressure changes when the Lev (Level) parameter of the AFTER TOUCH function in the VOICE COMMON mode is set to "on" (see page 33).

Settings: -3 ... 0 ... +3

Procedure: Use the [▷] key to move the cursor to the lower display line. Use the [-1/NO] and [+1/YES] keys to select the desired after touch sensitivity.

Details: Plus "+" settings produce higher output level in response to higher after touch pressure. Minus "-" settings produce the opposite effect:

lower level in response to higher pressure. A setting of "0" results in no level variation.

- 0 No response.
- +1 Narrow change between medium-high and high pressure.
- +2 Broader change between medium and high pressure.
- +3 Smooth change all the way from low to high pressure.

"-" Settings have the same effect, but the sound level decreases rather than increasing with increased after touch pressure. A graphic display to the right of the sensitivity value provides a visual clue as to the type of change produced by each setting.

Refer to: AFTER TOUCH, page 33.

TONE (FM Elements B and D Only)

```
ET▶TONE  ABCD
Lev= 0  FB=0
```

Summary: Adjusts the tone of the selected FM element — B or D.

Settings: Lev (Level): 0 ... 99
FB (Feedback): 0 ... 7

Procedure: Use the [◀] and [▷] cursor keys to place the underline cursor under the Lev or FB parameter. Use the [-1/NO] and [+1/YES] keys to set the level or feedback as required.

Details: The Lev parameter adjusts the modulation level of the select FM element, so higher values produce a brighter, sharper tone while lower values produce a rounder, more mellow tone. The effect of the feedback parameter varies from element to element, but in general higher values make the sound more brassy or noisy, while lower values make the sound smoother.

Refer to: WAVE TYPE, page 43.

LFO (Low Frequency Oscillator) AM Depth, PM Depth, Type, Delay, Rate & Speed

● *AM (Amplitude Modulation Depth)*



Summary: Determines the maximum amount of amplitude modulation that can be applied to the selected element by the modulation wheel or keyboard after touch.

Settings: 0... 15

Procedure: Use the [◀] and [▶] cursor keys to select the AM parameter. Use the [-1/NO] and [+1/YES] keys to set the desired degree of amplitude modulation.

Details: A "0" setting produces no modulation while a setting of "15" produces maximum modulation. Amplitude modulation produces a periodic variation in the volume of the sound, thus creating a tremolo effect. Please note that the AM parameter of the WHEEL and/or AFTER TOUCH function in the VOICE COMMON edit mode must be set to "on" before amplitude modulation can be applied manually (see page 33). Amplitude modulation is applied automatically when these parameters are off.

Refer to: WHEEL, page 32. AFTER TOUCH, page 33.

● *PM (Pitch Modulation Depth)*

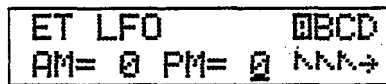

Summary: Determines the maximum amount of pitch modulation that can be applied to the selected element by the modulation wheel or keyboard after touch.

Settings: 0... 31

Procedure: Use the [◀] and [▶] cursor keys to select the PM parameter. Use the [-1/NO] and [+1/YES] keys to set the desired degree of pitch modulation.

Details: A "0" setting produces no modulation while a setting of "31" produces maximum modulation. Pitch modulation produces a periodic pitch variation, thereby creating a vibrato effect. Please note that the PM parameter of the WHEEL and/or AFTER TOUCH function in the VOICE COMMON edit mode must be set to "on" before pitch modulation can be applied manually. Pitch modulation is applied automatically when these parameters are off.

Refer to: WHEEL, page 32. AFTER TOUCH, page 33.

● *Type*

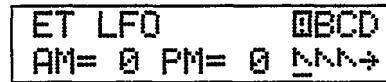

Summary: Determines the waveform of the LFO for the selected element.

Settings:

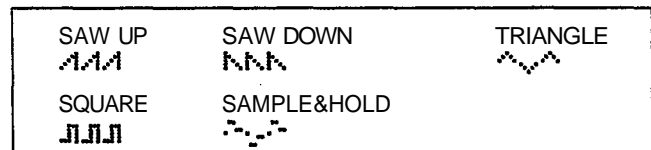

Procedure: Use the [◀] and [▶] cursor keys to select the waveform parameter. Use the [-1/NO] and [+1/YES] keys to select the desired LFO waveform.

Details:

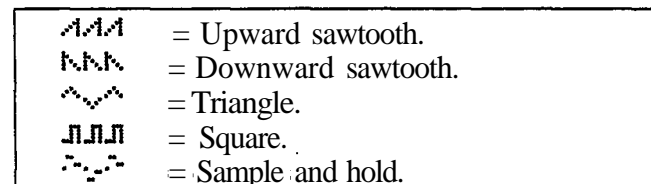

● *Dly (Delay)*

```
ET LFO      BCD
←Dly= 0 Rate= 0→
```

Summary: Sets the delay time between the beginning of a note and the beginning of LFO operation for the selected element when the WHEEL and AFTER TOUCH parameters in the VOICE COMMON edit mode are both turned off.

Settings: 0... 99

Procedure: Use the [◀] and [▶] cursor keys to select the Dly parameter. Use the [-1/NO] and [+1/YES] keys to set the desired LFO delay.

Details: The minimum setting "0" results in no delay, while the maximum setting of "99" produces maximum delay before the LFO begins operation.

Refer to: WHEEL, page 32. AFTER TOUCH, page 33.

● *Rate*

```
ET LFO      BCD
←Dly= 0 Rate= 0→
```

Summary: Sets the rate of LFO "fade in" for the selected element when the WHEEL and AFTER TOUCH parameters in the VOICE COMMON edit mode are both turned off.

Settings: 0 ... 99

Procedure: Use the [◀] and [▶] cursor keys to select the Rate parameter. Use the [-1/NO] and [+1/YES] keys to set the desired LFO fade-in rate.

Details: "0" is the fastest rate, causing the LFO to start operation at full depth immediately. A setting of 99 produces the longest LFO fade in.

Refer to: WHEEL, page 32. AFTER TOUCH, page 33.

● *Spd (Speed)*

```
ET LFO      BCD
←Spd= 0
```

Summary: Sets the speed of the LFO for the selected element.

Settings: 0...31

Procedure: Use the [◀] and [▶] cursor keys to select the Spd parameter. Use the [-1/NO] and [+1/YES] keys to set the desired LFO speed.

Details: "0" is slowest LFO speed setting; "31" is the fastest.

The speed parameter can not be edited when the sample-and-hold (·-·-·-·) LFO TYPE is selected.

ELEMENT ENVELOPE

The ELEMENT ENVELOPE edit mode allows detailed programming of the amplitude envelopes for each element in the selected voice.

TYPE	53
ENVELOPE COPY	54
DELAY (Delay Rate & ON/OFF)	54
INITIAL LEVEL	54
ATTACK (Level & Rate)	55
DECAY 1 (Level & Rate)	55
DECAY 2 (Level & Rate)	55
RELEASE RATE	56
LEVEL SCALING	56
RATE SCALING	57

ELEMENT ENVELOPE

Selecting the ELEMENT ENVELOPE Edit Mode

From the VOICE or MULTI mode:

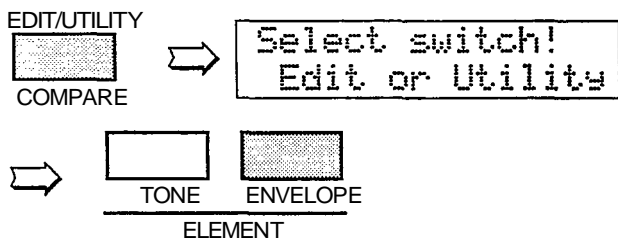

From another edit or utility mode simply press [ELEMENT ENVELOPE].

An "E" will appear to the left of the LED display to indicate that an edit mode is selected, and the element selected for editing will be displayed to the right of the display — "A", "b", "C", or "d". A dot will appear to the right of the element character as soon as any parameter has been edited.

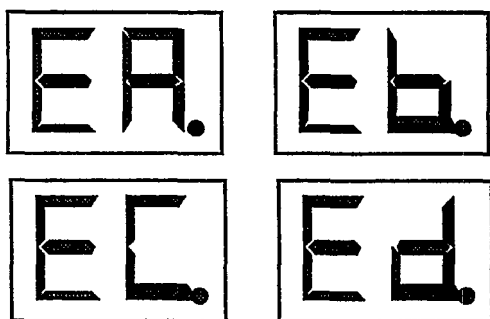

Different elements can be selected for editing by pressing the appropriate [ELEMENT SELECT] key — [A], [B], [C] or [D]. If a 2-element voice is being edited, only elements A and B can be selected.

Any of the available elements can also be turned on or off by pressing the appropriate [ELEMENT ON/OFF] key. Each key alternately turns the associated element on and off, and the on/off status of the elements is shown to the right of the upper LCD line. If the element character is showing, the associated element is ON, if a dash appears in place of the element

character, that element is OFF. The ability to turn elements on or off while editing makes it easier to hear the effect of parameter changes on a single element. The currently selected element is also shown on the LCD as a reversed (white on black) character.

In this example elements A, B and D are ON, while element C is OFF.
Element A is currently selected for editing.

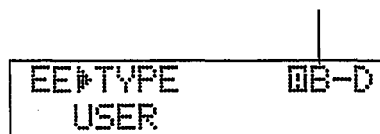

Selecting the ELEMENT ENVELOPE Edit Mode Functions

The various ELEMENT ENVELOPE edit mode functions can be selected in sequence by pressing the [ELEMENT ENVELOPE] key, or by using the [-1/NO] and [+1/YES] keys when the cursor (▷) is located immediately before the function name on the upper display line.

The COMPARE Function

You can compare the sound of the edited voice with the sound of the voice before it was edited by pressing the [EDIT/COMPARE] key to activate the COMPARE function. A "C" will appear on the LED display while the COMPARE function is active, and the sound of the voice prior to editing will be heard when you play the keyboard. Press the [EDIT/COMPARE] key again to return to the edit mode.

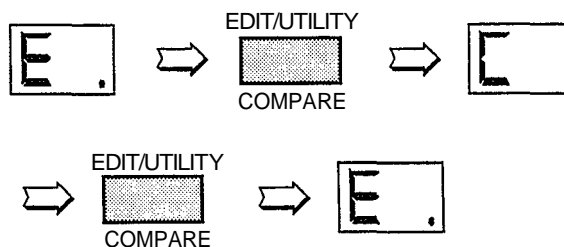

TYPE

```

EE TYPE  BCD
  USER
  
```

Summary: Selects a user or preset amplitude envelope for the selected element.

Settings: PRESET, PIANO, GUITAR, PLUCK, BRASS, STRINGS, ORGAN, USER

Procedure: Use the [▷] key to move the cursor to the lower display line. Use the [-1/NO] and [+1/YES] keys to select the desired envelope.

Details: When "PRESET" is selected, the original envelope of the wave selected for the current element is used. For example, if the current uses a guitar wave corresponding guitar envelope will be selected.

When "PIANO," "GUITAR," "PLUCK," "BRASS," "STRINGS," or "ORGAN" is selected, a generic envelope of the appropriate type is used. Then piano, organ and strings envelopes are roughly as shown below:

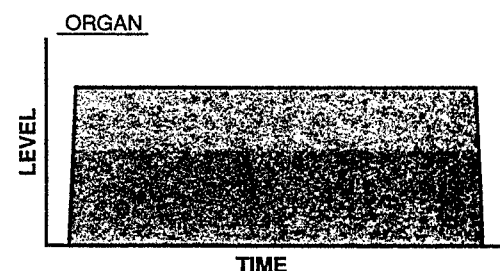
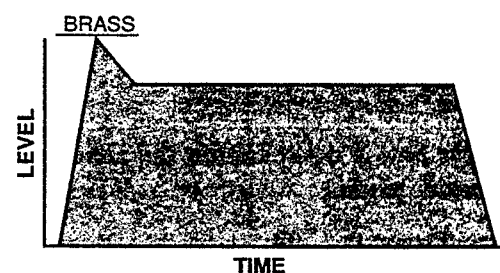
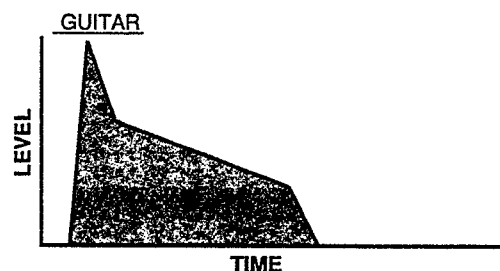
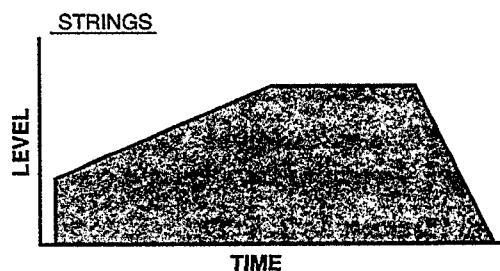
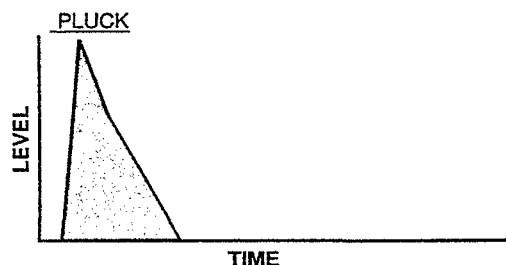
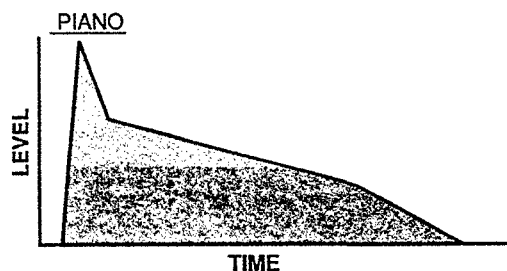

Editing any of the envelope parameters for one of the above types turns the envelope into a "USER" type.

When "USER" is selected, an original envelope can be programmed using the attack, decay, and release parameters described on pages 55, 56.

Refer to: Tutorial, page 25. ENVELOPE, page 33.

ENVELOPE COPY

```
EE▶COPYfrom 0BCD
any Element? →
```

Summary: Copies envelope parameters from a selected element to the current element.

Settings: Element: A, B, C, D

Procedure: Use the [◀] and [▶] cursor keys to move the cursor to the "from" element parameter. Use the [-1/NO] and [+1/YES] keys to select the element from which the envelope data is to be copied.

Press the [▶] cursor key one more time and the "Are you sure?" display will appear. Press [+1/YES] to execute the copy operation or [-1/NO] to cancel. "»Completed!!«" will appear briefly when the copy operation has finished.

Details: This function can save a lot of programming time by allowing easy copying of complex USER type envelope data between elements.

DELAY (Delay Rate & ON/OFF)

```
EE▶DELAY 0BCD
Rate= 0 off
```

Summary: Sets a delay before the envelopes of all elements begin.

Settings: Delay: 0 ... 99
Mode: on/off

Procedure: Use the [◀] and [▶] cursor keys to move the cursor to the "Rate" parameter. Use

the [-1/NO] and [+1/YES] keys to select the desired delay rate.

Press the [▶] cursor key one more time to move to the on/off mode parameter, and use the [-1/NO] and [+1/YES] keys to set as required.

Details: The envelope delay rate parameter affects all envelopes simultaneously. A setting of "0" produces almost no delay while a setting of "99" produces maximum delay.

INITIAL LEVEL

```
EE▶INITIAL 0BCD
Level= 0
```

Summary: Sets the starting level of the amplitude envelope for the current element.

Settings: 0... 99

Procedure: Use the [▶] cursor key to move the cursor to the lower display line. Use the [-1/NO] and [+1/YES] keys to set the initial level.

Details: A setting of "0" means that the envelope will begin from zero (minimum) level, while a setting of "99" causes the envelope to begin

immediately from maximum level. The highest setting produces the sharpest attack.

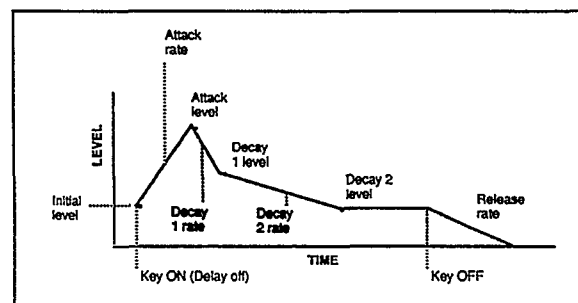

Refer to: ENVELOPE, page 33.

ATTACK (Level & Rate)

```
EE▶ATTACK  ▣BCD
AL= 0  AR= 0
```

Summary: Sets the rate and peak level of the attack of the amplitude envelope for the current element.

Settings: AL (Attack Level): 0 ... 99
AR (Attack Rate): 0 ... 99

Procedure: Use the [◀] and [▶] cursor keys to move the cursor to the "AL" or "AR" parameter. Use the [-1/NO] and [+1/YES] keys to set the selected level or rate parameter.

Details: Refer to the INITIAL LEVEL function for a complete envelope diagram.

A rate setting of "0" produces the slowest attack, and a setting of "99" produces the fastest attack.

A level setting of "0" produces the lowest attack level, while a setting of "99" produces the highest level.

Please note that the attack may be "biased" by the ENVELOPE Attack Rate parameter in the VOICE COMMON edit mode.

Refer to: ENVELOPE, page 33.

DECAY 1 (Level & Rate)

```
EE▶DECAY1  ▣BCD
D1L= 0  D1R= 0
```

Summary: Sets the rate and final level of the first decay of the amplitude envelope for the current element.

Settings: D1L (Decay 1 Level): 0 ... 99
D1R (Decay 1 Rate): 0 ... 99

Procedure: Use the [◀] and [▶] cursor keys to move the cursor to the "D1L" or "D1R" parameter.

Use the [-1/NO] and [+1/YES] keys to set the selected level or rate parameter.

Details: Refer to the INITIAL LEVEL function for a complete envelope diagram.

A rate setting of "0" produces the slowest decay, and a setting of "99" produces the fastest decay.

A level setting of "0" produces the lowest decay level, while a setting of "99" produces the highest level.

DECAY 2 (Level & Rate)

```
EE▶DECAY2  ▣BCD
D2L= 0  D2R= 0
```

Summary: Sets the rate and final level of the second decay of the amplitude envelope for the current element.

Settings: D2L (Decay 2 Level): 0 ... 99
D2R (Decay 2 Rate): 0 ... 99

Procedure: Use the [◀] and [▶] cursor keys to move the cursor to the "D2L" or "D2R" parameter. Use the [-1/NO] and [+1/YES] keys to set the selected level or rate parameter.

Details: Refer to the INITIAL LEVEL function for a complete envelope diagram.

A rate setting of "0" produces the slowest decay, and a setting of "99" produces the fastest decay.

ELEMENT ENVELOPE

A level setting of "0" produces the lowest decay level, while a setting of "99" produces the highest level.

The decay 2 level parameter also sets the hold level at which the note is sustained until released.

RELEASE RATE

```
EE*RELEASE  BCD
Rate= 0
```

Summary: Sets the release rate of the amplitude envelope for the current element.

Settings: 0 ... 99

Procedure: Use the [▷] cursor key to move the cursor to the lower display line. Use the [-1/NO] and [+1/YES] keys to set the release rate.

Details: Refer to the INITIAL LEVEL function for a complete envelope diagram.

A release rate setting of "0" produces the slowest release, and a setting of "99" produces the fastest release.

Please note that the release note may be "biased" by the ENVELOPE Release Rate parameter in the VOICE COMMON edit mode.

Refer to: ENVELOPE, page 33.

LEVEL SCALING

```
EE*SCALING  BCD
Lev Type= 1  ---
```

Summary: Determines how the level of the current element changes across the range of the keyboard.

Settings: 1 ... 16

Procedure: Use the [▷] cursor key to move the cursor to the lower display line. Use the [-1/NO] and [+1/YES] keys to set the desired level scaling curve.

Details: Most acoustic instruments do not produce a uniform sound level throughout their pitch range. This results in a level curve that can be simulated by appropriate settings of the level scaling parameter. Often, for example, the level decreases slightly as the pitch increases. Each of the 16 available level scaling curves is shown in graphic form on the LCD when selected, making it easy to locate and select the optimum curve for each application.

● Level Scaling LCD Graphic

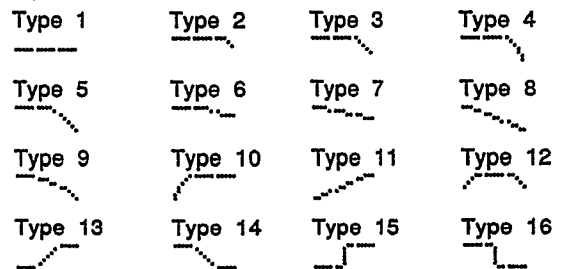

RATE SCALING

```
EE▶SCALING 0BCD
Rate Type=1  ---
```

Summary: Determines how the overall rate of the amplitude envelope for the current element changes across the range of the keyboard.

Settings: 1 ... 8

Procedure: Use the [▶] cursor key to move the cursor to the lower display line. Use the [-1/NO] and [+1/YES] keys to set the desired rate scaling curve.

Details: Many acoustic instruments do not produce uniform note length throughout their pitch range. This results in a rate curve that can be simulated by appropriate settings of the rate scaling parameter. Often, for example, the overall note length decreases slightly as the pitch increases. Each of the 8 available rate scaling curves is shown in graphic form on the LCD when selected, making it easy to locate and select the optimum curve for each application.

● *Rate Scaling LCD Graphic*

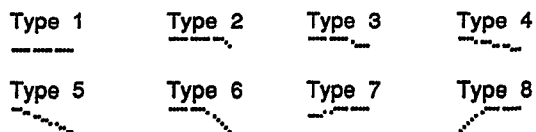

ELEMENT ENVELOPE

MULTI

The MULTI edit mode allows 8 different voices to be assigned to different MIDI channels. The assigned voices can then be individually controlled over the appropriate channels from an external MIDI sequence recorder or other controller. If a number of these channel/voice "parts" are assigned to the MIDI transmit channel of the SY22, they can all be played simultaneously from the SY22 keyboard. Individual characteristics of each voice, such as volume and detune, can also be programmed.

NAME	62
EFFECT (Type & Depth)	62
VOICE NUMBER	62
MIDI RECEIVE CHANNEL	63
VOLUME	63
DETUNE	64
NOTE LIMIT (Low & High)	64
NOTE SHIFT	64

MULTI

A Basic MULTI PLAY System

The SY22 MULTI PLAY (multi-timbre) mode allows up to 8 different voices to be individual assigned to any of 16 different MIDI channels. Each voice/channel assignment is known as a multi-play "part," just like the various parts in a

band or orchestra. You can then record multi-voice compositions on a MIDI sequence recorder and play them back using only the sequencer and SY22.

Here's an example of a sequencer recording and playback setup:

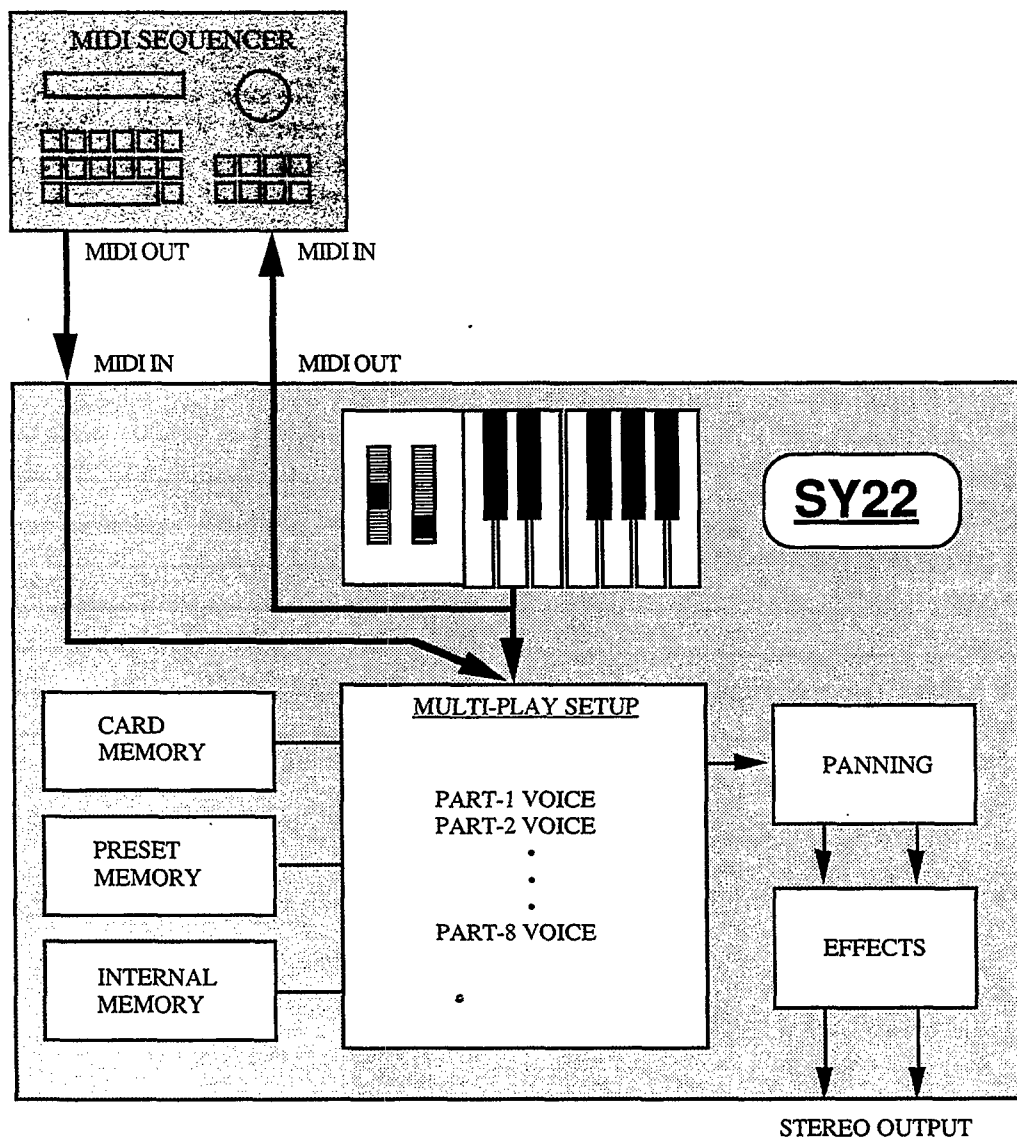

In addition to 16 PRESET multi-play setups, 16 INTERNAL memory locations are provided for complete multi-play setups including voice-to-channel assignments, voice volume, note shift, detune, note limits, and effects for each part. This allows you to create up to 16 original "orchestras" with different combinations of voices that can be recalled whenever needed.

Other Possibilities

The MULTI mode is useful even when a sequencer is not used. If you set the MIDI RECEIVE CHANNEL parameter (page 63) of several multi-play parts to the same channel that the SY22 is set to transmit on (TRANSMIT CHANNEL parameter, page 81), those parts can all be played simultaneously via the SY22

keyboard. By setting the low and high NOTE LIMIT parameters (page 64) of parts set to the keyboard channel to limit them to specific regions of the keyboard, it is also possible to create a range of split keyboard effects — e.g. play bass with the left hand and piano with the right.

MULTI PLAY Mode, Bank and Setup Selection

The MULTI mode, memory banks and individual multi-play setups are selected in the same way as the SY22 voices:

- [MULTI] to select the multi-play mode.
- [PRESET] or [INTERNAL] to select the desired memory.
- [BANK] and [NUMBER/MULTI PLAY PART] keys or [-1/NO] and [+1/YES] keys to select the desired multi-play setup.

Selecting the MULTI Edit Mode

From the VOICE or MULTI mode:

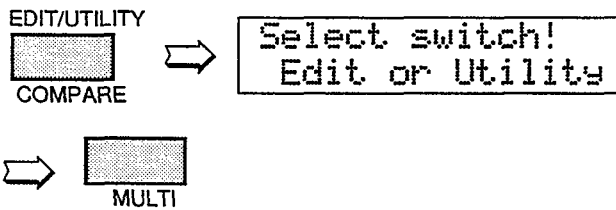

From another edit or utility mode simply press [MULTI].

An "E" will appear to the left of the LED display to indicate that an edit mode is selected, and the multi-setup part selected for editing will be displayed to the right of the display — "1" through "8." A dot will appear to the right of the part number as soon as any parameter has been edited.



Different parts can be selected for editing by pressing the appropriate [NUMBER/MULTI PART SELECT] key — [1] through [8].

Selecting the MULTI Edit Mode Functions

The various MULTI edit mode functions can be selected in sequence by pressing the [MULTI] key, or by using the [-1/NO] and [+1/YES] keys when the cursor (▷) is located immediately before the function name on the upper display line.

The COMPARE Function

You can compare the sound of the edited multi-play setup with the sound of the setup before it was edited by pressing the [EDIT/COMPARE] key to activate the COMPARE function. A "C" will appear on the LED display while the COMPARE function is active, and the sound of the setup prior to editing will be heard when you play the keyboard. Press the [EDIT/COMPARE] key again to return to the edit mode.

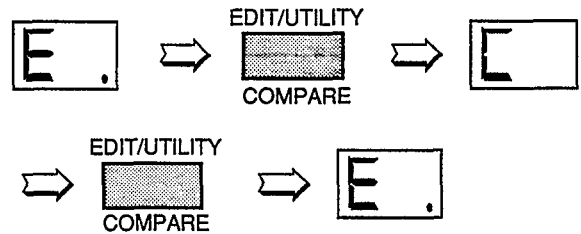

SY22 PRESET MULTI Performance Note

No.	Multi Name	Type	Comments	No.	Multi Name	Type	Comments
1	1.1 Orchestra	2 layer	Big Orchestra. Brass and strings.	9	2.1 FltCnrt	Split	Split flute and strings
2	1.2 SuperBrs	2 layer	Powerful brass.	10	2.2 Wb/Piano	Split	Split wood bass and piano.
3	1.3 StrPiano	2 layer	Piano with strings.	11	2.3 Fb/E.Pno	Split	Split fretless bass and E.Piano.
4	1.4 MonoLead	8 layer	Fat monoral synth lead.	12	2.4 RytmSect	Split	Split drum set and funky bass.
5	1.5 PinPad	3 layer	Synth decay pad.	13	2.5 <Pop>	MIDI multi	For Pop music.
6	1.6 SyncPad	4 layer	Fat synth pad.	14	2.6 <Rock>	MIDI multi	For Rock music.
7	1.7 PanPad	2 layer	Breathy synth Pan flute.	15	2.7 <Jazz>	MIDI multi	For Jazz music.
8	1.8 Haunted	Split	Image of haunted mansion.	16	2.8 <Demo>	MIDI multi	Used for SY22 Demo song.

MULTI

NAME

```
MU#NAME
P11 Initial
```

Summary: Assigns a name of up to 8 characters to the current multi-play setup.

Settings: The following characters are available for use in multi-play names:

```
(Space) !"#%&'()*+,-./0123456789:;<=>?@
ABCDEFGHIJKLMNPOQRSTUVWXYZ[\]^_`
abcdefghijklmnopqrstuvwxyz{|}~`
```

Procedure: Use the [◀] and [▶] cursor keys to place the underline cursor under the character to be changed. Use the [-1/NO] and [+1/YES] keys to select the desired character. Continue until the entire multi-play name has been programmed.

Details: It's a good idea to give your multi-play setups names that make them easily identifiable. If you've created a new setup using three voices intended for rock music, you could call it something like "RockTrio".

EFFECT (Type & Depth)

```
MU#EFFECT
Rev Hall Def=1
```

Summary: Selects one of sixteen digital effects, and sets the depth of the selected effect for the current multi-play setup.

Settings: Effect type:

Rev Hall	(Reverb Hall)
Rev Room	(Reverb Room)
Rev Plate	(Reverb Plate)
Rev Club	(Reverb Club)
Rev Metal	(Reverb Metal)
Delay 1	(Short Single Delay)
Delay 2	(Long Delay)
Delay 3	(Long Delay)
Doubler	(Doubler)
Ping-Pong	(Ping Pong Delay)
Pan Ref	(Panned Reflections)
Early Ref	(Early Reflections)
Gate Rev	(Gated Reverb)
Dly&Rev 1	(Delay & Reverb 1)
Dly&Rev 2	(Delay & Reverb 2)
Dist&Rev	(Distortion & Reverb)

Depth: 0... 7

Procedure: Use the [◀] and [▶] cursor keys to place the underline cursor under the effect type or depth parameter. Use the [-1/NO] and [+1/YES] keys to select the desired effect or effect depth.

Details: Setting the depth parameter to "0" is equivalent to turning the effect OFF. A depth setting of "7" produces the greatest effect.

Refer to: MULTI INITIALIZE, page 72.

VOICE NUMBER

```
MU#VOICE NUMBER
I11 Initial
```

Summary: Assigns a preset, card or internal voice to the selected multi-play part.

Settings: Source: I, C, P

Bank: 1 ... 8

Number: 1 ... 8

Procedure: Press the [NUMBER/MULTI PART SELECT] key corresponding to the desired multi-play part.

Use the [◀] and [▶] cursor keys to move the cursor to the source, bank, or number parameter.

Use the [-1/NO] and [+1/YES] keys to set the selected parameter as necessary.

Details: In this display the source, bank, and number parameters are shown in the standard SY22 voice number format. "P12," for example, is preset bank 1, number 2; "I35" is internal bank 3, number 5, etc.

Refer to: MULTI INITIALIZE, page 72.

MIDI RECEIVE CHANNEL

```
MU MIDI Rcv.ch
channel= 1
```

Summary: Sets the MIDI receive channel for the selected multi-play part to any channel between 1 and 16, or off.

Settings: 0 ... 16, off

Procedure: Press the [NUMBER/MULTI PART SELECT] key corresponding to the desired multi-play part.

Use the [▶] cursor key to move the cursor to the lower display line. The [-1/NO] and [+1/YES] keys are used to select the desired MIDI channel or turn MIDI reception for that part off.

Details: The most logical and easy-to-follow settings for multi-play parts 1 through 8 are, naturally, MIDI channels 1 through 8. Turn MIDI reception "off" for parts you do not intend to use.

Refer to: MULTI INITIALIZE, page 72.

VOLUME

```
MU VOLUME
Level= 0
```

Summary: Adjusts the volume of the selected multi-play part.

Settings: 0... 99

Procedure: Press the [NUMBER/MULTI PART SELECT] key corresponding to the desired multi-play part.

Use the [▶] cursor key to move the cursor to the lower display line. Use the [-1/NO] and [+1/YES] keys to select the desired volume level.

Details: A setting of "0" produces no sound while a setting of "99" produces maximum volume. The ability to independently adjust the volume of each multi-play part makes it simple to set up the optimum balance or "mix" between parts.

Refer to: MULTI INITIALIZE, page 72.

DETUNE

```
MU▶DETUNE
  0cent
```

Summary: Allows slight upward or downward pitch adjustment of the selected multi-play part.

Settings: -50...0...+50

Procedure: Press the [NUMBER/MULTI PART SELECT] key corresponding to the desired multi-play part. Use the [▶] cursor key to move the cursor to the lower display line. Use the [-1/NO] and [+1/YES] keys to select the desired amount of detuning.

Details: The Detune function allows different parts in a multi-play setup to be slightly detuned in relation to each other, thereby "thickening" the overall sound.

Detuning occurs in 3 or 4-cent steps. Since 100 cents equals one semitone, the overall detune range is approximately one semitone. Plus settings tune upward from normal pitch, and minus settings tune downward. A setting of "0" produces normal pitch.

Refer to: MULTI INITIALIZE, page 72.

NOTE LIMIT (Low & High)

```
MU▶NOTE LIMIT
Low= C2 High= G8
```

Summary: Sets the low and high note limits for the selected multi-play part.

Settings: C-2... G8

Procedure: Press the [NUMBER/MULTI PART SELECT] key corresponding to the desired multi-play part. Use the [◀] and [▶] cursor keys to select the Low or High parameter. The [-1/NO] and [+1/YES] keys are used to set the low or high note limit.

Details: The C-2 to G8 range of this function covers a full 10-1/2 octaves. "C3" corresponds to "middle C" on a keyboard.

This function allows the sound from a multi-play part to be limited to a specific region of the keyboard. If the Low Note Limit is set to C3 and the High Note Limit is set to C4, for example, the sound from that part will only be produced between C3 and C4 — the octave immediately above middle C. This makes it simple to produce split voices.

If the High Note Limit is set to a note that is *lower* than the Low Note Limit, the keys between the limits will produce no sound while all others will operate normally.

Refer to: MULTI INITIALIZE, page 72.

NOTE SHIFT

```
MU▶NOTE SHIFT
  0
```

Summary: Shifts the pitch of the selected multi-play part up or down in semitone steps.

Settings: -24...0...+24.

Procedure: Press the [NUMBER/MULTI PART SELECT] key corresponding to the desired multi-play part.

Use the [▷] cursor key to move the cursor to the lower display line. Use the [-1/NO] and [+1/YES] keys to select the desired degree of note shift.

Details: A setting of "-12," for example, shifts the pitch of the selected voice down by one octave; a setting of "+4" shifts the pitch up by a major third. The maximum range is plus or minus two octaves.

The Note Shift function can be used to transpose a voice to its most useful range, or to create harmony (intervals) between different parts in a multi-play setup.

Refer to: MULTI INITIALIZE, page 72.

UTILITY SETUP

The UTILITY SETUP mode provides access to a range of basic utility functions that are essential for general operation of the SY22.

MASTER TUNE	69
TRANSPOSE	69
MEMORY CARD (Save, Load, Format, & Bank)	69
VOICE INITIALIZE	71
MULTI INITIALIZE	72
MEMORY PROTECT (Internal & Card)	73

UTILITY SETUP

Selecting the UTILITY SETUP Mode

From the VOICE or MULTI mode:

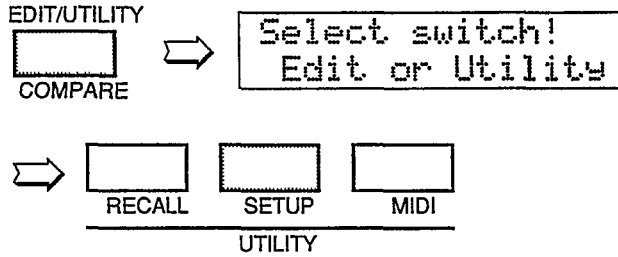

From another edit or utility mode simply press [UTILITY SETUP].

A "U" will appear on the LED display to indicate that a utility mode has been selected



Selecting the UTILITY SETUP Mode Functions

The various UTILITY SETUP mode functions can be selected in sequence by pressing the [UTILITY SETUP] key, or by using the [-1/NO] and [+1/YES] keys when the cursor (▷) is located immediately before the function name on the upper display line.

MASTER TUNE

```
SU MASTER TUNE
  0cent
```

Summary: Tunes the overall pitch of the SY22 over approximately a 100-cent range.

Settings: -50 ...0...+50

Procedure: Use the [▷] key to move the cursor to the lower display line. Use the [-1/NO] and [+1/YES] keys to set the desired degree of tuning.

Details: Tuning occurs in 3 or 4-cent steps. Since 100 cents equals one semitone, the overall tuning range is approximately one semitone — i.e. plus or minus a quarter tone. Plus settings tune upward from normal pitch, and minus settings tune downward. A setting of "0" produces normal pitch.

TRANSPOSE

```
SU TRANSPOSE
  0
```

Summary: Transposes the overall pitch of the SY22 up or down in semitone steps.

Settings: -12 ...0...+12

Procedure: Use the [▷] key to move the cursor to the lower display line. Use the [-1/NO] and [+1/YES] keys to set the desired degree of transposition.

Details: A setting of "-12," for example, transposes down by one octave; a setting of "+4" transposes up by a major third.

MEMORY CARD (Save, Load, Format, & Bank)

- *Save*

```
SU CARD
  SAVE
```

Summary: Saves all internal voice and multi-play data to a memory card.

Settings: SAVE

Procedure: Use the [▷] key to move the cursor to the lower display line, then use the [-1/NO] and [+1/YES] keys to select "SAVE." Now press the [▷] key again and the "SAVE TO CARD?" display will appear. Press the [+1/YES] key to start the save operation, or the [-1/NO] key to

cancel. "*****SAVE NOW*****" will appear on the display while the operation is in progress, and "»Completed!!«" will appear briefly when the save operation has finished.

Details: The SAVE operation can only be executed if the CARD parameter of the MEMORY PROTECT function described on page 73 is turned "off," and the WRITE PROTECT switch of the MCD32 or MCD64 Memory Card loaded in into the CARD slot is turned "off."

When an MCD64 Memory Card is used, the bank to which the data is to be save can be selected using the BANK function described on page 70.

UTILITY SETUP

Exercise caution when saving data to a memory card — the previous card data will be erased and completely replaced by the saved data.

Refer to: Tutorial, page 12.

•Load

```
SU CARD
▶LOAD
```

Summary: Loads voice and multi-play data from a memory card into the SY22 internal memory.

Settings: LOAD

Procedure: Use the [▷] key to move the cursor to the lower display line, then use the [-1/NO] and [+1/YES] keys to select "LOAD." Now press the [▷] key again and the "LOAD from CARD?" display will appear. Press the [+1/YES] key to start the load operation, or the [-1/NO] key to cancel. "****LOAD NOW****" will appear on the display while the operation is in progress, and "»Completed!!«" will appear briefly when the load operation has finished.

Details: The LOAD operation can only be executed if the INTERNAL parameter of the MEMORY PROTECT function described on page 73 is turned "off."

When an MCD64 Memory Card is used, the bank from which the data is to be loaded can be selected using the BANK function described on page 70.

Exercise caution when loading data from a memory card — the corresponding internal SY22 data will be erased and completely replaced by the loaded data.

Refer to: Tutorial, page 12.

•Format

```
SU CARD
▶FORMAT
```

Summary: Formats MCD64 or MCD32 Memory Cards so that they can be used by the SY22 to save and load voice and multi-play data.

Settings: FORMAT

Procedure: Use the [▷] key to move the cursor to the lower display line, then use the [-1/NO] and [+1/YES] keys to select "FORMAT." Now press the [▷] key again and the "FORMAT ?" display will appear. Press the [+1/YES] key to start the format operation, or the [-1/NO] key to cancel. "»Completed!!«" will appear briefly when the format operation has finished.

Details: Formatting can only be carried out if the memory card WRITE PROTECT switch is turned OFF (refer to your MCD64 or MCD32 Memory Card instructions for details).

Refer to: Tutorial, page 12.

•Bank

```
SU CARD
▶BANK 1
```

Summary: Selects bank 1 or bank 2 of a Yamaha MCD64 type memory card prior to formatting or load/save operations.

Settings: 1,2

Procedure: Use the [▷] key to move the cursor to the lower display line, then use the [-1/NO] and [+1/YES] keys to select "BANK." Now press the [▷] key again to move the cursor to the bank number. Use the [-1/NO] and [+1/YES] keys to select the desired bank.

Details: MCD32 memory cards only have a single bank, so bank 2 cannot be selected if this type of card is used. MCD64 memory cards allow selection of bank 1 or 2. Each bank holds 64 voices and 16 multi-play setups.

Refer to: Tutorial, page 12.

VOICE INITIALIZE

SUMINIT. VOICE

Summary: Initializes all parameters of the current voice.

Settings: None.

Procedure: After selecting the "INIT. VOICE" display, press the [▷] key. "Are you sure?" will

appear on the lower line of the display. Press the [+1/YES] to initialize or [-1/NO] to cancel the initialize operation.

"»Completed!!«" will appear briefly when the initialization is finished.

Details: When Voice Initialize is executed, the voice parameters are initialized to the following values:

	A	B	C	D
COMMON				
VOICE NAME	Initial			
CONFIGURATION	A-B-C-D			
EFFECT	Rev. Hall			
	1			
PITCH BEND	2			
WHEEL	off			
	on			
AFTER TOUCH	off			
	off			
	0			
	off			
ENVELOPE	0			
	0			
	0			
VECTOR				
VECTOR LEVEL SPEED	30ms) 50 STEP		
STEP(X)/TIME	1 0 0 End			
	2			
	:			
	50			
VECTOR DETUNE SPEED	30ms) 50 STEP		
STEP(X)/TIME	1 0 0 End			
	2			
	:			
	50			
ELEMENT TONE				
WAVE	000:PIANO:PIANO	151:OSC1 :sin8'	039:Str:Vn.Ens	152:OSC1 :sin4'
FREQ. shift	0	0	0	0
VOLUME	99	99	99	99
PAN	L-I-R	L-I-R	L-I-R	L-I-R
VELOCITY Sense	2	2	2	2
AFTER Sense	0	0	0	0
TONE Lev	—	92	—	92
TONE FB	—	0	—	0
LFO AM	0	0	0	0
LFO PM	16	16	16	16
LFO TYPE	∩∩	∩∩	∩∩	∩∩
LFO Dly	0	0	0	0
LFO Rate	99	99	99	99
LFO Spd	20	20	20	20

UTILITY SETUP

	A	B	C	D
ELEMENT ENV				
TYPE	PRESET	PRESET	PRESET	PRESET
DELAY Rate	0	0	0	0
DELAY ELE.	off	off	off	off
INITIAL Level	67	0	90	0
ATTACK AL	99	92	97	92
ATTACK AR	99	99	64	99
DECAY1 D1L	99	92	95	92
DECAY1 D1R	0	0	32	0
DECAY2 D2L	0	92	95	92
DECAY2 D2R	26	0	0	0
RELEASE Rate	60	76	52	76
SCALING Lav Type	2	1	4	1
Rate Type	3	1	2	1

The voice initialize function is useful if you want to begin programming a voice "from scratch."

MULTI INITIALIZE

SUM INIT. MULTI

Summary: Initializes all parameters of the current multi-play setup.

Settings: None.

Procedure: After selecting the "INIT. MULTI" display, press the [▷] key. "Are you sure?" will

appear on the lower line of the display. Press the [+1/YES] to initialize or [-1/NO] to cancel the initialize operation.

"»Completed!«" will appear briefly when the initialization is finished.

Details: When multi-play Initialize is executed, the multi-play setup parameters are initialized to the following values:

SY22 MULTI INITIAL

	PART1	PART2	PART3	PART4	PART5	PART6	PART7	PART8
NAME	Initial							
EFFECT	RevHall							
EFFECT Dep	1							
VOICE NUMBER	P12 DXlegend	P37 RokOrgan	P45 BrasSect	P63 Strings	P15Itopia	P67 Marimba	P62 Syn Bass	P88Dr.Kit
MIDI Rcv.ch	1	2	3	4	5	6	7	16
VOLUME	99	99	99	99	99	99	99	99
DETUNE	0	0	0	0	0	0	0	0
NOTE LIMIT Low	C-2	C-2	C-2	C-2	C-2	C-2	C-2	C-2
NOTE LIMIT High	G8	G8	G8	G8	G8	G8	G8	G8
NOTE SHIFT	0	0	0	0	0	0	0	0

The multi initialize function is useful if you want to begin programming a voice "from scratch."

SY22 System Parameter

<i>SETUP</i>	
MASTER TUNE	0
TRANSCOPE	0
CARD BANK	1
<i>MIDI</i>	
MIDI	on
BASIC Rcv.CH	1
TRANSMIT CH	1
LOCAL	on
PROG.CHANGE	off
CTRL.CHANGE	off
AFTER TOUCH	off
PITCH BEND	off
EXCLUSIVE	off

MEMORY PROTECT (Internal & Card)

```
SUMEM. PROTECT
INT=on  CARD=on
```

Summary: Turns internal or card memory protection on or off.

Settings: INT: on, off
CARD: on, off

Procedure: Use the [◀] and [▶] cursor keys to select the INT or CARD parameter. Use [-1/NO] and [+1/YES] keys to turn memory protection on or off.

Details: When INT memory protection is "on," the internal memory is protected and voice store operations to the internal memory cannot be carried out. The same applies to card memory: when protection is "on" memory card save operations will be blocked even if the memory card WRITE PROTECT switch is turned OFF.

Refer to: Tutorial, page 22.

UTILITY SETUP

UTILITY RECALL

The UTILITY RECALL mode accesses the VOICE or MULTI recall function, depending on whether the VOICE or MULTI play mode is selected when the RECALL function is called. RECALL makes it possible to recover a voice or multi-play setup that has been "lost" through failure to store the voice or multi-play setup prior to selecting a different voice or multi-play setup.

UTILITY RECALL

Selecting the UTILITY RECALL Mode

From the VOICE or MULTI mode:

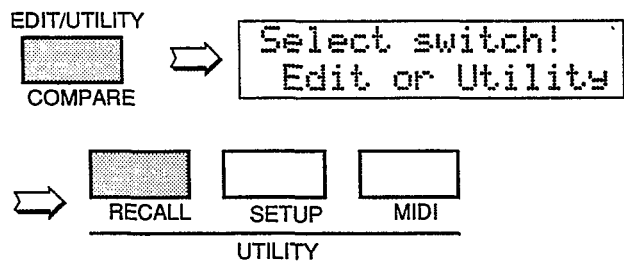

From another edit or utility mode simply press [UTILITY RECALL].

A "U" will appear on the LED display to indicate that a utility mode has been selected



VOICE RECALL (Voice or Multi)

```
RC RECALL VOICE  
Are you sure?
```

Summary: Recalls the last voice or multi-play setup edited from the SY22 edit buffer memory.

Settings: None

Procedure: The "RECALL VOICE" function is selected if called from the VOICE play mode, while "RECALL MULTI" function is selected if called from the MULTI play mode. "Are you sure?" appears on the lower display line. Press the [+1/YES] key to recall or [-1/NO] to cancel the recall operation.

Details: Even if you've exited the edit mode and called a different voice or multi-play setup, this function will recall the last voice or multi-play setup edited with all parameters as they were at the time the edit mode was exited.

UTILITY RECALL

UTILITY MIDI

The UTILITY MIDI mode provides access to all of the SY22's MIDI control functions.

MIDI ON/OFF.....	81
BASIC RECEIVE CHANNEL.....	81
TRANSMIT CHANNEL.....	81
LOCAL CONTROL ON/OFF.....	82
MIDI PROGRAM CHANGE.....	82
MIDI CONTROL CHANGE.....	82
AFTER TOUCH ON/OFF.....	83
PITCH BEND ON/OFF.....	83
EXCLUSIVE ON/OFF.....	83
ALL V/M TRANSMIT.....	84
1 VOICE TRANSMIT.....	84

UTILITY MIDI

Selecting the UTILITY MIDI Mode

From the VOICE or MULTI mode:

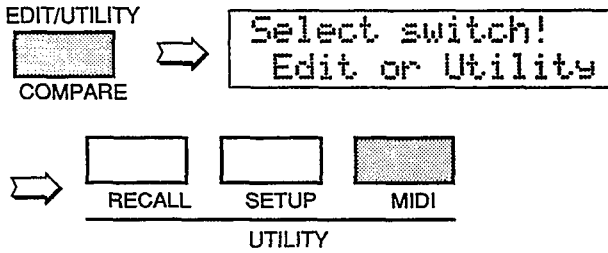

From another edit or utility mode simply press [UTILITY MIDI].

A "U" will appear on the LED display to indicate that a utility mode has been selected.



Selecting the UTILITY MIDI Mode Functions

The various UTILITY MIDI mode functions can be selected in sequence by pressing the [UTILITY MIDI] key, or by using the [-1/NO] and [+1/YES] keys when the cursor (▷) is located immediately before the function name on the upper display line.

MIDI ON/OFF

```
MD▶MIDI
midi=on
```

Summary: Turns all MIDI control functions on or off.

Settings: on, off

Procedure: Use the [▷] cursor key to move the cursor to the lower display line. Use the [-1/NO] and [+1/YES] keys to turn MIDI control on or off.

Details: MIDI control can be turned "off" to prevent unwanted interference from external MIDI devices connected to the SY22, and/or to prevent the SY22 from affecting operation of the external equipment.

BASIC RECEIVE CHANNEL

```
MD▶BASIC Rcv.CH
channel= 1
```

Summary: Sets the SY22 MIDI receive channel to any channel between 1 and 16, or the "omni" mode for reception on all channels.

Settings: 1 ... 16, omni

Procedure: Use the [▷] cursor key to move the cursor to the lower display line. The [-1/NO]

and [+1/YES] keys are used to select the desired MIDI channel or the omni mode.

Details: When the SY22 is to receive data from an external MIDI device such as a sequencer, make sure that the SY22 MIDI receive channel is either set to the channel that the external device is transmitting on, or the omni mode.

TRANSMIT CHANNEL

```
MD▶TRANSMIT CH
channel= 1
```

Summary: Sets the MIDI transmit channel for the SY22.

Settings: 1 ... 16.

Procedure: Use the [▷] cursor key to move the cursor to the lower display line. Use the [-1/NO] and [+1/YES] keys to select the desired MIDI transmit channel number.

Details: The MIDI transmit channel job is used primarily to match the transmit channel of the SY22 with the receive channel of an external MIDI device being driven by the SY22. When a multi-play setup is selected, however, the MIDI transmit channel setting also determines which of the setup's voices is played via the SY22 keyboard.

LOCAL CONTROL ON/OFF

```
MD#LOCAL
Local=on
```

Summary: Determines whether the SY22 keyboard controls the internal tone generator system or not.

Settings: on, off.

Procedure: Use the [▷] cursor key to move the cursor to the lower display line. Use the [-1/NO] and [+1/YES] keys to turn local control on or off.

Details: Normally, local control will be turned "on" so that the SY22 keyboard plays its own internal tone generator system. If you want to control an external MIDI tone generator or other device from the SY22 keyboard *without* playing the internal tone generator, turn local control "off." One possibility is to drive the SY22 tone generator system from an external sequencer while independently playing a separate external tone generator from the SY22 keyboard.

MIDI PROGRAM CHANGE

```
MD#PROG.CHANGE
=off
```

Summary: Determines how the SY22 will respond to MIDI program change messages for remote voice/multi selection.

Settings: off, common, individual

Procedure: Use the [▷] cursor key to move the cursor to the lower display line. The [-1/NO] and [+1/YES] keys are used to select the desired MIDI program change mode.

Details: The "off" setting turns MIDI program change reception and transmission off, so MIDI program change messages received from external equipment will not cause the corresponding SY22 voice to be selected, and no program

change messages will be transmitted by the SY22 when one of its voices are selected.

In the "common" mode, program change numbers 0 through 63 received from external equipment will select SY22 voices 1.1 through 8.8, and program change numbers 64 through 79 select multi-play setups 1.1 through 2.8. The card, internal or preset voice banks cannot be selected via MIDI control. The corresponding program change number will also be transmitted by the SY22 when one of its voices are selected. The "individual" mode allows individual voice selection for each multi-play part when the MULTI play mode is active. Program change between 0 and 63 received in a specific MIDI channel will change only the voice for the multi-play part assigned to that channel.

MIDI CONTROL CHANGE

```
MD#CTRL.CHANGE
=off
```

Summary: Determines whether or not the SY22 will receive and transmit MIDI control change messages.

Settings: off, on

Procedure: Use the [▷] cursor key to move the cursor to the lower display line. The [-1/NO] and [+1/YES] keys are used to turn control change reception/transmission on or off.

Details: The "off" setting turns MIDI control change reception and transmission off so that

control change messages corresponding to modulation, pitch, volume and other functions will be ignored by the SY22 when received, and the SY22 will not transmit any control change messages.

AFTER TOUCH ON/OFF

```
MD▶AFTER TOUCH
=on
```

Summary: Turns keyboard after touch on or off.

Settings: on, off.

Procedure: Use the [▷] cursor key to move the cursor to the lower display line. Use the [-1/NO] and [+1/YES] keys to turn after touch on or off.

Details: When after touch is turned "off," internal SY22 after touch will function normally but no MIDI after touch data will be transmitted or received.

Keyboard after touch generates a tremendous amount of MIDI data, so you might want to turn after touch "off" when recording to a MIDI sequencer in order to preserve memory capacity.

PITCH BEND ON/OFF

```
MD▶PITCH BEND
=on
```

Summary: Turns pitch bend control on or off.

Settings: on, off.

Procedure: Use the [▷] cursor key to move the cursor to the lower display line. Use the [-1/NO]

and [+1/YES] keys to turn pitch bend control on or off.

Details: When pitch bend control is turned "off," the SY22 pitch bend wheel will function normally but no MIDI pitch bend wheel data will be transmitted or received.

EXCLUSIVE ON/OFF

```
MD▶EXCLUSIVE
=on
```

Summary: Turns transmission/reception of MIDI system exclusive data on or off.

Settings: on, off.

Procedure: Use the [▷] cursor key to move the cursor to the lower display line. Use the [-1/NO] and [+1/YES] keys to exclusive transmission/reception on or off.

UTILITY MIDI

Details: MIDI system exclusive data is transmitted by the SY22 when one of the voice transmit functions described below is used. The same type of data will also be automatically loaded into the SY22 memory when received from a second SY22 or other MIDI device, thus erasing

previous data. This function can be turned "off" to prevent accidental erasure of the internal memory, or the memory of external equipment, do to mistaken data reception or transmission.

ALL V/M TRANSMIT

```
MD▶ALL V/M TRANS
ALL Voice&Multi
```

Summary: Initiates MIDI bulk transmission of all voice and multi-play data.

Settings: None

Procedure: Use the [▶] key to move the cursor to the lower display line. "Are you sure?" will appear on the display. Press the [+1/YES] key to begin transmission, or the [-1/NO] key to cancel. "Transmitting!!" will appear on the display during transmission, and ">>Completed!!<<" will appear briefly when transmission has finished.

Details: This function is useful for transferring all the voice and multi-play data from one SY22 to another. If the MIDI OUT of the transmitting SY22 is connected to the MIDI IN of the receiving SY22 via a MIDI cable, the receiving unit will automatically receive and load the data as long as its internal memory protect function is turned "off" and EXCLUSIVE ON/OFF is turned "on." Another possibility is to transfer the data to a MIDI bulk data storage device for long-term storage.

1 VOICE TRANSMIT

```
MD▶1 VOICE TRANS
I11 Yes/No ?
```

Summary: Initiates bulk transmission of the data for a specified SY22 voice.

Settings: Source: I, C, P
Bank: 1 ... 8
Number: 1 ... 8

Procedure: Use the [◀] and [▶] cursor keys are used to move the cursor to the source, bank, or number parameter. Use the [-1/NO] and [+1/YES] keys to set the selected parameter as necessary. When the desired voice number has been selected, move the cursor to the Yes/No? parameter and press the [+1/YES] key to begin transmission.

"Transmitting!!" will appear on the display during transmission, and ">>Completed!!<<" will appear briefly when transmission has finished.

Details: Like the ALL V/M TRANSMIT function described above, the 1 VOICE TRANSMIT function is ideal for transferring voice from one SY22 to another, or to a MIDI bulk storage device for long-term storage.

In this display the source, bank and number parameters are shown in the standard SY22 voice number format. "P12," for example, is preset bank 1, number 2; "I35" is internal bank 3, number 5, etc.

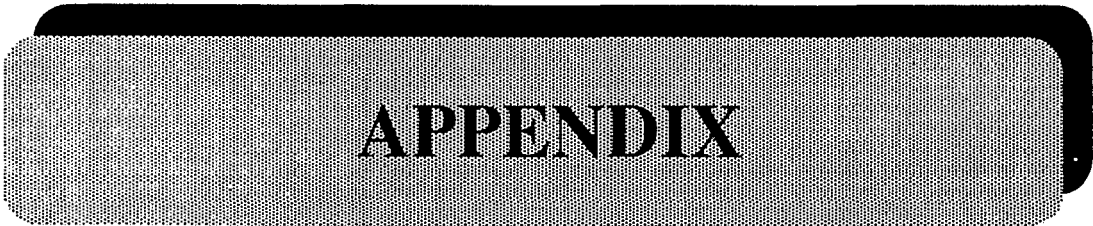

APPENDIX

SPECIFICATIONS

Keyboard: 61 keys, initial and after-touch response.

Tone Generator Systems: AWM (Advanced Wave Memory) & FM (Frequency Modulation).

Internal Memory:

Wave ROM; 128 preset AWM & 256 preset FM waveforms.

Preset ROM; 64 preset voices.

Internal RAM; 64 user voices.

External Memory: Voice & Multi data; MCD64 or MCD32 memory cards + write & read.

Displays:

16-character x 2-line backlit LCD.

7-segment 2-digit LED display.

Controls: VOLUME, VECTOR CONTROL, PITCH BEND, MODULATION.

Key & Switches: POWER; VECTOR PLAY ON/OFF, LEVEL/DETUNE; CURSOR ◀ and ▶; MODE VOICE and MULTI; -1/NO and +1/YES; EDIT/UTILITY/COMPARE; STORE; INTERNAL, CARD, PRESET; BANK 1-8 (VOICE COMMON and VECTOR; ELEMENT TONE and ENVELOPE; MULTI; UTILITY RECALL, SETUP and MIDI); NUMBER/MULTI PART SELECT 1-8 (ELEMENT SELECT A-D, ELEMENT ON/OFF A-D); DEMO.

Connectors: DC 10V-12V IN; PHONES; OUTPUT R & L/MONO, FOOT VOLUME, SUSTAIN.

MIDI Connectors: IN, OUT, THRU.

Power requirements:

DC10-12V, 500mA

Dimensions (W x H x D):

976 x 285 x 93 mm (37-7/8" x 11-1/4" x 3-5/8")

Weight: 6.8 kg (14 lbs 16 oz)

ERROR MESSAGES

Things do go wrong from time to time, and people do make mistakes. When an error occurs, the SY22 will usually display a message that describes the type of error so you can easily take steps to rectify the problem. The following are quick summaries of the SY22 error displays.

VOICE PLAY XXX NO DATA!	VOICE PLAY (XXX=MEMORY, BANK, NUMBER)
----------------------------	---

MULTI NO DATA!	MULTI PLAY
----------------	------------

EDIT NO DATA!	EDIT
------------------	------

MEMORY STORE NO DATA!	STORE
--------------------------	-------

SU CARD NO DATA!	SET UP (CARD LOAD)
---------------------	-----------------------

The currently loaded memory contains no data or data that is not recognizable by the SY22.

VOICE PLAY Card not ready!	VOICE PLAY
-------------------------------	------------

MULTI XXXXXXXXX Card not ready!	MULTI PLAY (XXXXXXXXXX= MULTI NAME)
------------------------------------	---

Card not ready! "NO" to Exit	STORE
---------------------------------	-------

SU CARD Card not ready!	SET UP (CARD SAVE/LOAD/ FORMAT)
----------------------------	---------------------------------------

You have attempted to execute a memory card-related operation but no card is inserted in the CARD slot.

VOICE PLAY Card not format!	VOICE PLAY
--------------------------------	------------

MULTI XXXXXXXXX Card not format!	MULTI PLAY (XXXXXXXXXX= MULTI NAME)
-------------------------------------	---

Card not format! "NO" to Exit	STORE
----------------------------------	-------

SU CARD Card not format!	SET UP (CARD SAVE)
-----------------------------	-----------------------

The currently loaded memory card is not properly formatted for use with the SY22.

Memory Protected "NO" to Exit	STORE
----------------------------------	-------

SU CARD Memory Protected	SET UP (CARD SAVE/LOAD/ FORMAT)
-----------------------------	---------------------------------------

You have attempted to execute an operation that will affect the card or internal memory, but the v=card and/or internal memory protect function is turned ON.

VOICE PLAY Change Card Bank	VOICE PLAY
--------------------------------	------------

MULTI XXXXXXXXX Change Card Bank	MULTI PLAY (XXXXXXXXXX= MULTI NAME)
-------------------------------------	---

Change Card Bank "NO" to Exit	STORE
----------------------------------	-------

SU CARD Change Card Bank	SET UP (SAVE/LOAD/ FORMAT)
-----------------------------	----------------------------------

An MCD32 type memory card is loaded but card bank 2 is selected (MCD32 cards only have a single bank — BANK 1 — so it is necessary to select bank 1 if this display appears).

*ERROR**Hit "NO"* Illegal Data

Unrecognizable MIDI bulk data has been received by the SY22.

INDEX

-1/NO and +1/YES Keys			
	3,13,30,36,42,52,61,68, 80		
A			
After Touch			
Amplitude Modulation	33		
Level Control	33		
Pitch Modulation	33		
Pitch Control	33		
Amplitude Modulation	32		
AWM (Advanced Wave Memory)	14		
B			
Bank Select & Edit/Utility Mode Keys	4,12-13		
C			
Card Slot	6,12,69		
Compare Function	30,36,42,52,61		
Cursor Keys	3		
D			
DC 10V-12V in Jack	5,9		
Demo Key	4,10		
Drum Kit Voice	19		
E			
Edit/Utility/Compare Key	3,20,24,30,36,42,52,61,68, 80		
Envelope			
Attack (Level & Rate)	33,55		
Copy	54		
Delay (Delay Rate & Element On/Off)	54		
Decay 1 (Level & Rate)	55		
Decay 2 (Level & Rate)	55		
Global Attack	33		
Global Release	33		
Initial Level	33,54		
Level Scaling	56		
Release Rate	33,56		
Rate Scaling	57		
Type	25, 33, 53		
Element			
After Touch Sensitivity		33,47	
Copy		45	
Frequency Shift		45	
Pan		46	
Tone		47	
Velocity Sensitivity		46	
Volume		46	
F			
FM Synthesis		14	
Foot Volume Jack		6	
K			
Keyboard		3	
L			
LED Display		4	
LFO (Low Frequency Oscillator)			
AM Depth		32,33,48	
PM Depth		32, 33,48	
Type		48	
Delay		32,33,49	
Rate		32,33,49	
Speed		49	
Liquid Crystal Display		4	
M			
Master Tune		69	
Memory Card		6,12,69	
Memory Keys (Internal, Card, Preset)		4,11-12	
Memory Protect		22,73	
MIDI			
1 Voice Transmit		84	
After Touch On/Off		83	
All Voice & Multi Transmit		84	
Basic Receive Channel		81	
Control Change		82	
Exclusive On/Off		83	
In, Out and Thru Connectors		6	
Local Control On/Off		82	
On/Off		81	
Program Change		82	
Pitch Bend On/Off		83	

Transmit Channel	81
Modulation Wheel	3, 32,48,49, 83
Multi Key & Indicator	3,60-61
Multi Play Mode	59-61
Detune	64
Effect Type & Depth	62
Initialize	72
MIDI Receive Channel	63
Name	62
Note Limit	64
Note Shift	64
Recall	75-77
Sequencer System	60
Split Keyboard Setups	60
Voice Number Assignments	62
Volume	63

N

Number/Multi Part Select Keys	4,12-13,61
-------------------------------	------------

O

Output R & L/Mono Jacks	6
-------------------------	---

P

Phones Jack	5
Pitch Bend Wheel	3,32, 83
Pitch Modulation	32
Power Switch	5
Precautions	2

R

Random	
Detune	24,34
Element	24,34
Level	24,34
Reference Section, What's In the	1

S

Store Key	4,23
Sustain Jack	6

T

Transpose	69
Tutorial Section, What's In the	1

V

Vector	
Control	3,11,14-21
Detune Speed	21,39
Detune Record	21,39
Detune Edit (Step, X-Axis, Y-axis & Time)	21-23,39
Level Speed	20,37
Level Record	21,37
Level Edit (Step, X-Axis, Y-axis & Time)	21-23,37
Play Keys & Indicators	3,15
Voice	
Configuration	14,31
Effect Depth	31
Effect Type	13,16-19,31
Initialize	71
Key & Indicator	3,12,22
Name	23,31
Preset List	11,16-19
Volume Control	3,9

W

Wave	
AWM List	43
FM List	44
Type	14,16-19,43

MIDI DATA FORMAT

O DATA FORMAT

(1) MIDI reception conditions

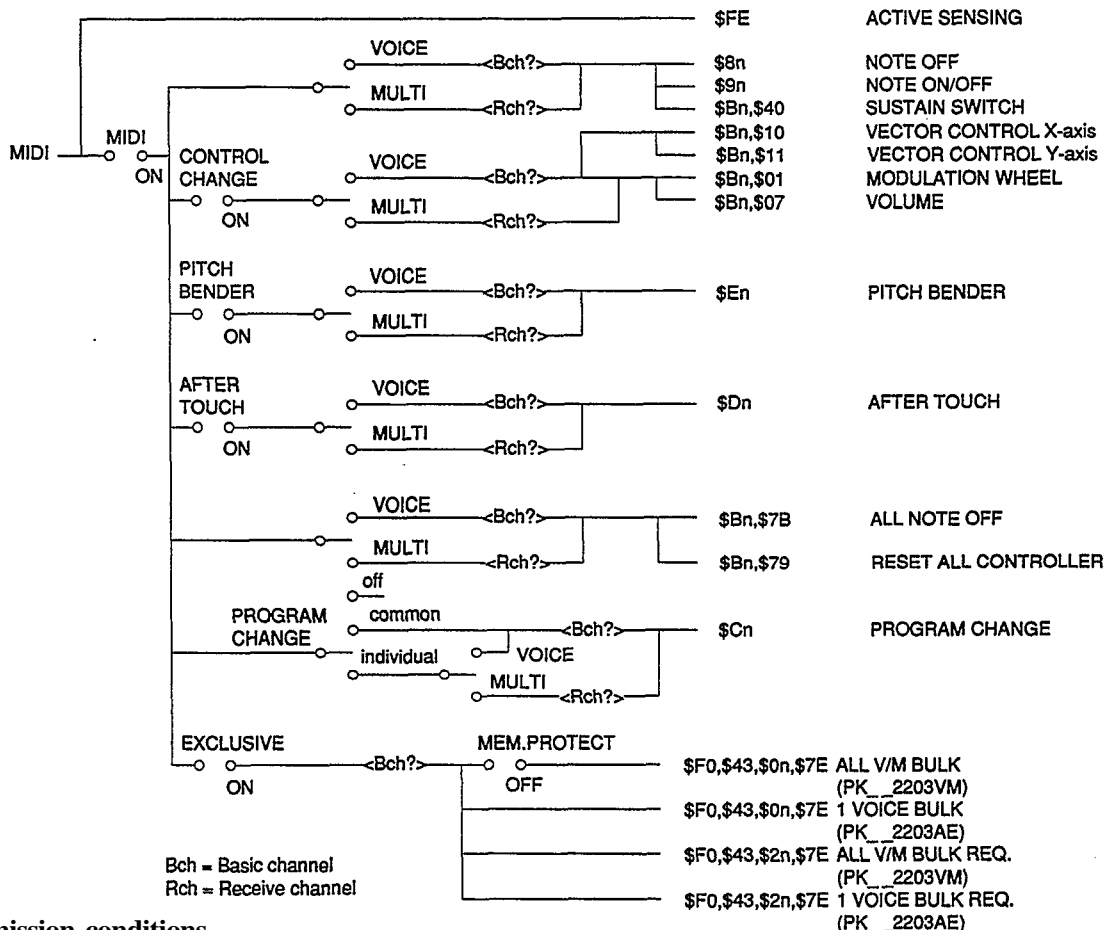

(2) MIDI transmission conditions

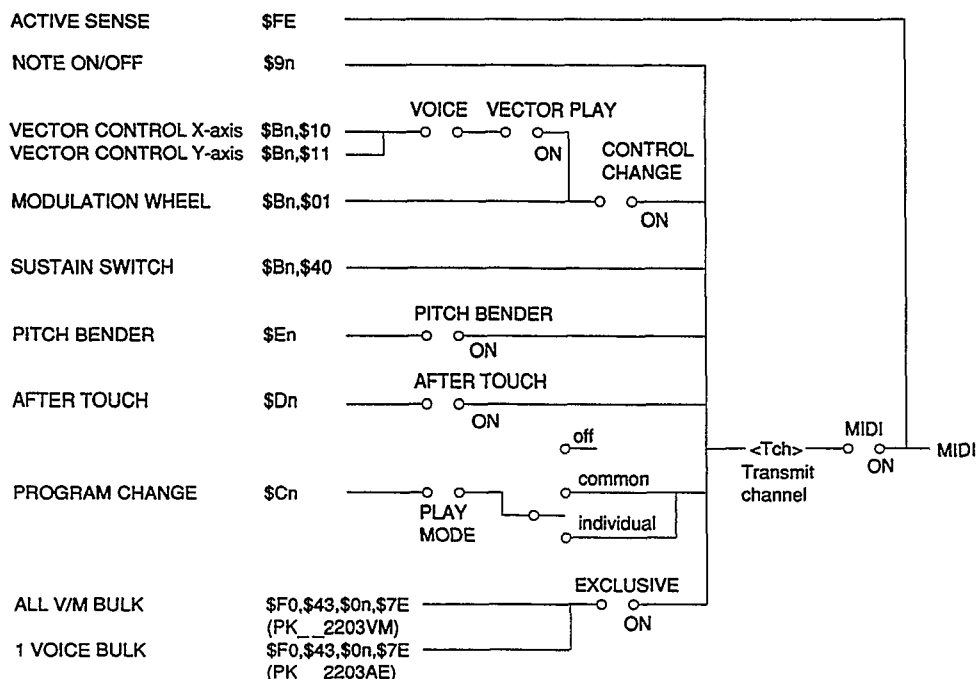

APPENDIX

(3) Channel Messages

3.1 Note On/Off

Transmission:

- Note range = C1(\$24)~C6(\$60)
- Velocity range = 0~\$7F (0: note off)
- \$9n, note, \$00 for note off and \$8n is not transmitted.

Reception:

- Note range = C-2(\$00)~G8(\$7F)
- Velocity range = 0~\$7F

3.2 Control Change

MODULATION WHEEL and VECTOR CONTROL is possible to set transmission/reception on/off by the utility control change on/off.

Transmission:

- Output to MIDI through the transmit channel when the following controller is operated irrespective of the play, edit, etc. mode.

controller	code	output data range
MODULATION WHEEL	\$Bn,\$01,\$w	w = 0~\$7F
SUSTAIN SWITCH	\$Bn,\$40,\$w	off:w=0, on:w=\$7F
VECTOR CONTROL X-axis Y-axis	\$Bn,\$10,\$w \$Bn,\$11,\$w	w=0~\$7F w=0~\$7F

- VECTOR CONTROL is transmitted only if the VECTOR PLAY ON/OFF switch on the panel is on.

Reception:

- The following parameters are accepted by MIDI.

parameter	code	Description
MODULATION WHEEL	\$Bn,\$01,\$w	w=0(WHEEL:MIN)~\$7F(WHEEL:MAX)
SUSTAIN SWITCH	\$Bn,\$40,\$w	w=0~\$3F:SUS OFF, w=\$40~\$7F:SUS ON
VOLUME	\$Bn,\$07,\$w	
VECTOR CONTROL X-axis Y-axis	\$Bn,\$10,\$w \$Bn,\$11,\$w	Depends on the panel [VECTOR PLAY ON/OFF] and [LEVEL/DETUNE] status.

3.3 Program Change

- It is possible to set transmit/receive on/off by the utility program change on/off.

Transmission:

- The voice and multi Nos. and the program change Nos. correspond to each other as shown below.

		NUMBER							
		1	2	3	4	5	6	7	8
VOICE	1	\$00	\$01	\$02	\$03	\$04	\$05	\$06	\$07
	2	\$08	\$09	\$0A	\$0B	\$0C	\$0D	\$0E	\$0F
	3	\$10	\$11	\$12	\$13	\$14	\$15	\$16	\$17
	B	\$18	\$19	\$1A	\$1B	\$1C	\$1D	\$1E	\$1F
	A	\$20	\$21	\$22	\$23	\$24	\$25	\$26	\$27
	11	\$28	\$29	\$2A	\$2B	\$2C	\$2D	\$2E	\$2F
	K	\$30	\$31	\$32	\$33	\$34	\$35	\$36	\$37
	8	\$38	\$39	\$3A	\$3B	\$3C	\$3D	\$3E	\$3F
MULTI	1	\$40	\$41	\$42	\$43	\$44	\$45	\$46	\$47
	2	\$48	\$49	\$4A	\$4B	\$4C	\$4D	\$4E	\$4F

Reception:

- The above program change Nos. are accepted. Other Nos. are ignored.

3.4 Pitch Bend

- It is possible to set transmission/reception on/off by the utility pitch bend on/off.

Transmission:

- Transmitted at 7-BIT resolution.

Reception:

- Operates by 7 BIT on the MSB side only. The LSB side is ignored.

3.5 After Touch

- It is possible to set transmission/reception on/off by the utility after touch on/off.

Channel mode message

Reception:

- With the following codes, receive is possible in each of the voice and multi modes and the corresponding channel process is performed.

Not accepted if OMNI ON, however.

The NOTE OFF process is restricted to the MIDI input NOTE only.

ALL NOTE OFF \$Bn, \$7B, \$00

RESET ALL CONTROLLER \$Bn, \$79, \$00

(4) System Common Message

- At statuses \$F1~\$F6, nothing is done.
- At status \$F7, "END OF SYSTEM EXCLUSIVE".

(5) System Realtime Message

Transmission:

- \$FE is transmitted about every 270 msec,

Reception:

- If no signal comes from MIDI for about 300 msec or more after once receiving \$FE, the MIDI receive buffer is cleared and the MIDI KEY ON is turned OFF.

(6) System Exclusive Messages

4.1 1 VOICE BULK DUMP

Transmission:

The voice data set by input is transmitted.

Reception:

The received data is saved in the voice edit buffer.

Format:

\$F0	%11110000	Status	
\$43	%01000011	Yamaha	
\$0n	%0000nnnn	n-Receive or Transmit channel	
\$7E	%01111110		
\$06	%0nnnnnnn	BYTE Count (MSB)	
\$21	%0nnnnnnn	BYTE Count (LSB)	
\$50	%01010000	ASCII 'P	} Byte count shows this area.
\$4B	%01001011	ASCII 'K	
\$20	%00100000	ASCII '-'	
\$20	%00100000	ASCII '-'	
\$32	%00110010	ASCII '2	
\$32	%00110010	ASCII '2	
\$30	%00110000	ASCII '0	
\$33	%00110011	ASCII '3	
\$41	%01000001	ASCII 'A	
\$45	%01000101	ASCII 'E	
\$dd	%0ddddddd	} 1 VOICE DATA	
\$dd	%0ddddddd		
\$ee	%0eeeeeee	CHECK SUM	
\$F7	%11110111	EOX	

4.2 ALL V/M BULK DUMP

Transmission:

All the internal voice and multi data is transmitted.

Reception:

The received data is internally saved.

Format:

\$F0	%11110000	Status	
\$43	%01000011	Yamaha	
\$0n	%0000nnnn	n-Receive or Transmit channel	
\$7E	%01111110		
\$18	%0nnnnnnn	BYTE Count (MSB)	
\$66	%0nnnnnnn	BYTE Count (LSB)	
\$50	%01010000	ASCII 'P	} Byte count shows this area.
\$4B	%01001011	ASCII 'K	
\$20	%00100000	ASCII '-'	
\$20	%00100000	ASCII '-'	
\$32	%00110010	ASCII '2	
\$32	%00110010	ASCII '2	
\$30	%00110000	ASCII '0	
\$33	%00110011	ASCII '3	
\$56	%01010110	ASCII 'V	
\$4D	%01001101	ASCII 'M	
\$dd	%0ddddddd	} VOICE DATA (00-03)	
\$dd	%0ddddddd		
\$ee	%0eeeeeee	CHECK SUM	
-----100 msec WAIT-----			
\$18	%0nnnnnnn	BYTE Count (MSB)	
\$5C	%0nnnnnnn	BYTE Count (LSB)	
\$dd	%0ddddddd	} VOICE DATA (04-07)	
\$dd	%0ddddddd		
\$ee	%0eeeeeee	CHECK SUM	
-----100 msec WAIT-----			
Voice data is transmitted as divided per 4 timbres as shown above. A time interval of a minimum of 100 msec is always allocated between them.			
-----100 msec WAIT-----			
\$09	%0nnnnnnn	BYTE Count (MSB)	
\$00	%0nnnnnnn	BYTE Count (LSB)	
\$dd	%0ddddddd	} MULTI DATA (00-15)	
\$dd	%0ddddddd		
\$ee	%0eeeeeee	CHECK SUM	
\$F7	%11110111	EOX	

4.3.1 VOICE BULK REQUEST

Reception:

The request signal of the above Item 4.1. However, the data transmitted by this request is the timbre No. sounded at VOICE instead of being the one set as specified in Item 4.1.

Format:

\$F0	%11110000	Status	
\$43	%01000011	Yamaha	
\$2n	%0010nnnn	n-Receive channel	
\$7E	%01111110		
\$50	%01010000	ASCII 'P	
\$4B	%01001011	ASCII 'K	
\$20	%00100000	ASCII '-'	
\$20	%00100000	ASCII '-'	
\$32	%00110010	ASCII '2	
\$32	%00110010	ASCII '2	
\$30	%00110000	ASCII '0	
\$33	%00110011	ASCII '3	
\$41	%01000001	ASCII 'A	
\$45	%01000101	ASCII 'E	
\$F7	%11110111	EOX	

4.4 ALL V/M BULK REQUEST

Reception:

The request signal of the above Item 4.2.

Format:

\$F0	%11110000	Status	
\$43	%01000011	Yamaha	
\$2n	%0010nnnn	n-Receive channel	
\$7E	%01111110		
\$50	%01010000	ASCII 'P	
\$4B	%01001011	ASCII 'K	
\$20	%00100000	ASCII '-'	
\$20	%00100000	ASCII '-'	
\$32	%00110010	ASCII '2	
\$32	%00110010	ASCII '2	
\$30	%00110000	ASCII '0	
\$33	%00110011	ASCII '3	
\$56	%01010110	ASCII 'V	
\$40	%01001101	ASCII 'M	
\$F7	%11110111	EOX	

Function	Transmitted	Recognized	Remarks
Basic Default	1-16	1-16	memorized
Channel Changed	1-16	1-16	
Mode Default	3	1, 3	memorized
Mode Messages	X	X	
Mode Altered	*****	X	
Note Number : True voice	36-96 *****	0 -127 19-114	
Velocity Note on	0 9nH, v=1-127	0 v=1-127	
Velocity Note off	X 9nH, v=0	X	
After Key's	X	X	
Touch Ch's	0	*3 0	*3
Pitch Bender	0	*2 0 0-12 semi	*2: 7bit resolution
Control 1	0	*1 0	*1: Modulation wheel
Control 7	X	*1 0	*1: Volume
Control 16	0	*1 0	*1: Vector control X
Control 17	0	*1 0	*1: Vector control Y
Control 64	0	*1 0	*1: Sustain
Program Change : True #	0 0-79 *****	0 0-79 0-79	
System Exclusive	0	*4 0	*4
System : Song Pos	X	X	
System : Song Sel	X	X	
Common : Tune	X	X	
System : Clock	X	X	
Real Time: Commands	X	X	
Aux : Local ON/OFF	X	X	
Aux : All Notes OFF	X	0 (123)	
Mes- : Active Sense	0	0	
sages: Reset	X	X	
Notes :	*1 = transmit/receive if control change sw is on.		
	*2 = transmit/receive if pitch bend sw is on.		
	*3 = transmit/receive if after touch sw is on.		
	*4 = transmit/receive if exclusive sw is on.		
Mode 1	OMNI ON, POLY	Mode 2	OMNI ON, MONO
Mode 3	OMNI OFF, POLY	Mode 4	OMNI OFF, MONO
			0 : Yes
			X : No

IMPORTANT SAFETY AND INSTALLATION INSTRUCTIONS

INFORMATION RELATING TO POSSIBLE PERSONAL INJURY, ELECTRIC SHOCK, AND FIRE HAZARD POSSIBILITIES HAS BEEN INCLUDED IN THIS LIST.

WARNING — When using electronic products, basic precautions should always be followed, including the following:

1. Read all Safety and Installation Instructions, Supplemental Marking and Special Message Section data, and any applicable assembly instructions **BEFORE** using this product.
2. Check unit weight specifications **BEFORE** you attempt to move this product.
3. Main power supply verification. Yamaha Digital Musical Instrument products are manufactured specifically for use with the main supply voltage used in the area where they are to be sold. The main supply voltage required by these products is printed on the name plate. For name plate location please refer to the graphic in the Special Message section. If any doubt exists please contact the nearest Yamaha Digital Musical Instrument retailer.
4. Some Yamaha Digital Musical Instrument products utilize external power supplies or adapters. Do **NOT** connect products of this type to any power supply or adapter other than the type described in the owners manual or as marked on the unit.
5. This product may be equipped with a plug having three prongs or a polarized line plug (one blade wider than the other). If you are unable to insert the plug into the outlet, contact an electrician to have the absolute outlet replaced. Do **NOT** defeat the safety purpose of the plug. Yamaha products not having three prong or polarized line plugs incorporate construction methods and designs that do not require line plug polarization.
6. **WARNING** — Do **NOT** place objects on the power cord or place the unit in a position where any one could walk on, trip over, or roll anything over cords of any kind. An improper installation of this type can create the possibility of a fire hazard and/or personal injury.
7. Environment: Your Yamaha Digital Musical Instrument should be installed away from heat sources such as heat registers and/or other products that produce heat.
8. Ventilation: This product should be installed or positioned in a way that its placement or location does not interfere with proper ventilation.
9. Yamaha Digital Musical Instrument products are frequently incorporated into "Systems" which are assembled on carts, stands, or in racks. Utilize only those carts, stands, or racks that have been designed for this purpose and observe all safety precautions supplied with the products. Pay special attention to cautions that relate to proper assembly, heavier units being mounted at the lower levels, load limits, moving instructions, maximum usable height and ventilation.
10. Yamaha Digital Musical Instrument products, either alone or in combination with amplification, headphones, or speakers, may be capable of producing sound levels that could cause permanent hearing loss. Do **NOT** operate at high volume levels or at a level that is uncomfortable. If you experience any discomfort, ringing in the ears, or suspect any hearing loss, you should consult an audiologist.
11. Do **NOT** use this product near water or in wet environments. For example, near a swimming pool, spa, in the rain, or in a wet basement.
12. Care should be taken so that objects do not fall, and liquids are not spilled into the enclosure.
13. Yamaha Digital Musical Instrument products should be serviced by a qualified service person when:
 - a. The power supply/power adapter cord or plug has been damaged; or
 - b. Objects have fallen, or liquid has been spilled into the product; or
 - c. The unit has been exposed to rain; or
 - d. The product does not operate, exhibits a marked change in performance; or
 - e. The product has been dropped, or the enclosure of the product has been damaged.
14. When not in use, always turn your Yamaha Digital Musical Instrument equipment "OFF". The power supply cord should be unplugged from the outlet when the equipment is to be left unused for a long period of time. **NOTE:** In this case, some units may lose some user programmed data. Factory programmed memories will not be affected.
15. Electromagnetic Interference (RFI). Yamaha Digital Musical Instruments utilize digital (high frequency pulse) technology that may adversely affect Radio/TV reception. Please read FCC Information (rear cover) for additional information.
16. Do **NOT** attempt to service this product beyond that described in the user maintenance section of the owners manual. All other servicing should be referred to qualified service personnel.

**PLEASE KEEP THIS MANUAL
FOR FUTURE REFERENCE!**

This information on safety is provided to comply with U.S.A. laws, but should be observed by users in all countries.

SPECIAL MESSAGE SECTION

ELECTROMAGNETIC INTERFERENCE (RFI): Your Yamaha Digital Musical Instrument Proapplicable regulations. However, if it is Installed in the immediate proximity of other electronic devices, some form of interference may occur. For additional RFI information see FCC Information section located in this manual.

IMPORTANT NOTICE: This product has been tested and approved by independent safety testing laboratories in order that you may be sure that when it is properly installed and used in its normal and customary manner, all foreseeable risks have been eliminated. **DO NOT** modify this unit or commission others to do so unless specifically authorized by Yamaha. Product performance and/or safety standards may be diminished. Claims filed under the expressed warranty may be denied if the unit is/has been modified. Implied warranties may also be affected.

SPECIFICATIONS SUBJECT TO CHANGE: The information contained in this manual is believed to be correct at the time of printing. Yamaha reserves the right to change or modify specifications at any time without notice or obligation to update existing units.

NOTICE: Service charges incurred due to a lack of knowledge relating to how a function or effect works (when the unit is operating as designed), are not covered by the manufacturer's warranty. Please study this manual carefully before requesting service.

NAMEPLATE LOCATION: The graphic below indicates the location of the Name Plate on your Yamaha Digital Musical Instrument. The Model, Serial Number, Power requirements, etc., are Indicated on this plate.

You should note the model, serial number and the date of purchase in the spaces provided below and retain this manual as a permanent record of your purchase.

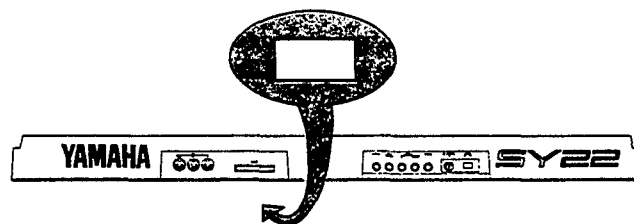

STATIC ELECTRICITY CAUTION: Some Yamaha Digital Musical Instrument products have modules that plug into the unit to perform various function. The contents of a plug-in module can be altered/damaged by static electricity discharges. Static electricity build-ups are more likely to occur during cold winter months (or in areas with very dry climates) when the natural humidity is low. To avoid possible damage to the plug-in module, touch any metal object (a metal desk lamp, a door knob, etc.) before handling the module. If static electricity is a problem in your area, you may want to have your carpet treated with a substance that reduces static electricity build-up. See your local carpet retailer for professional advice that relates to your specific situation.

Model _____

Serial No. _____

Purchase Date _____

This information on safety is provided to comply with U.S.A. laws, but should be observed by users in all countries.

FCC INFORMATION

While the following statements are provided to comply with FCC Regulations in the United States, the corrective measures listed below are applicable worldwide.

This series of Yamaha professional music equipment uses frequencies that appear in the radio frequency range and if installed in the immediate proximity of some types of audio or video devices (within three meters), interference may occur. This series of Yamaha professional music equipment has been type tested and found to comply with the specifications set for a class B computing device in accordance with those specifications listed in subpart J of part 15 of the FCC rules. These rules are designed to provide a reasonable measure of protection against such interference. However, this does not guarantee that interference will not occur. If your professional music equipment should be suspected of causing interference with other electronic devices, verification can be made by turning your professional music equipment off and on. If the interference continues when your equipment is off, the equipment is not the source of interference. If your equipment does appear to be the source of the interference, you should try to correct the situation by using one or more of the following measures:

Relocate either the equipment or the electronic device that is being affected by the interference. Utilize power outlets for the professional music equipment and the device being affected that are on different branch (circuit breaker or fuse) circuits, or install AC line filters.

In the case of radio or TV interference, relocate the antenna or, if the antenna lead-in is 300 ohm ribbon lead, change the lead-in to co-axial type cable.

If these corrective measures do not produce satisfactory results, please contact your authorized Yamaha professional products dealer for suggestions and/or corrective measures.

If you cannot locate a franchised Yamaha professional products dealer in your general area contact the Electronic Service Division, Yamaha Corporation of America, 6600 Orangethorpe Ave., Buena Park, CA 90620, U.S.A.

If for any reason, you should need additional information relating to radio or TV interference, you may find a booklet prepared by the Federal Communications Commission helpful: "How to Identify and Resolve Radio-TV Interference Problems". This booklet is available from the U.S. Government Printing Office, Washington D.C. 20402 - Stock No. 004-000-00345-4.

SERVICE

This product is supported by YAMAHA's worldwide network of factory trained and qualified dealer service personnel. In the event of a problem, contact your nearest YAMAHA dealer.

YAMAHA

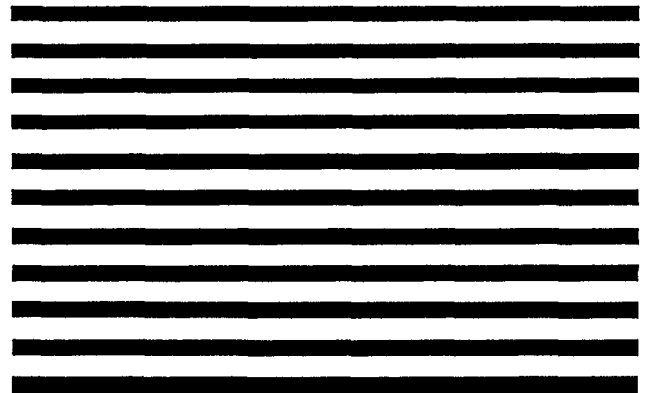

YAMAHA CORPORATION
PO Box 1, Hamamatsu, Japan

VI93520 9042 R4 ITP Printed Japan

YAMAHA[®]

Yamaha Corporation of America
6600 Orangethorpe Avenue, P.O. Box 6600, Buena Park, CA 90622-6600



Recyclable



Recycled